



EDUS 39 - 605A - C

R-410A

# Engineering Data



# Controls



**DAIKIN AC (AMERICAS), INC.**

# Controls

1. Control Systems.....	2
2. Control Devices.....	3
2.1 BRC1C71 Wired Remote Controller.....	3
2.2 BRC4C / 7C / 7E Wireless Remote Controller / Receiver .....	11
2.3 BRC2A71 Simplified Remote Controller.....	13
2.4 DCS302C71 Central Remote Controller .....	16
2.5 DCS301C71 Unified ON/OFF Controller.....	40
2.6 DST301BA61 Schedule Timer .....	48
2.7 BRC1D71 7-Day Programmable Controller .....	55
2.8 DCS601C71 intelligent Touch Controller .....	62
3. Adaptors.....	74
3.1 KRCS01-1 Remote Sensor .....	74
3.2 DTA104A 53/ 61/ 62 Required Outdoor Unit External Control Adaptor ..	75
3.3 DTA109A51 DIII NET Expander Adaptor .....	77
3.4 KRP1B71 / 72 / 73 Adaptor for wiring .....	80
3.5 KRP4A71 / 72 / 73 / 74 Wiring Adaptor for Electrical Appendices .....	82
3.6 DCS302A72 Unification Adaptor for Computerized Control.....	87

# 1. Control Systems

## Optional Accessories of Operation Control System

No.	Item	Type	FXFQ~MVJU	FXSQ~MVJU	FXMQ~MVJU	FXAQ~MVJU	FXLQ~MVJU FXNQ~MVJU	FXHQ~MVJU	FXDQ~MVJU
1	Remote controller	Wireless	BRC7C812	BRC4C82		BRC7E818	—	BRC7E83	BRC4C82
		Wired	BRC1C71						
2	Wired 7-day programmable remote controller	BRC1D71							
3	Remote sensor	KRCS01-1							
4	Installation box for adaptor PCB	KRP1B98	—				KRP1C93	KRP1B101	
5	Central remote controller	DCS302C71							
5-1	Electrical box	KJB311A							
6	Unified on/off controller	DCS301C71							
6-1	Electrical box	KJB212A							
7	Schedule timer	DST301BA61							
8	External control adaptor for outdoor unit	DTA104A62★	DTA104A61		—	DTA104A61	DTA104A62★	DTA104A53★	
9	D3-NET Expander adaptor	DTA109A51							
10	Simplified remote controller	—	BRC2A71		—	BRC2A71	—	BRC2A71	
11	Adaptor for wiring	KRP1B72★	KRP1B71				KRP1B73★	—	
12	Wiring adaptor for electrical appendices (2)	KRP4A73★	KRP4A71				KRP4A72★	KRP4A74★	

C:3D043022C

### Notes:

\*1. Installation box (No.4) is necessary for each adaptor marked with an asterisk. 2. LONWORKS® is a registered trade mark of Echelon Corporation.

## Building management system

	Part name			Model No.	Function
Intelligent Touch Controller	Basic	Hardware	intelligent Touch Controller	DCS601C71	Air-Conditioning management system that can be controlled by a compact all-in-one unit.
	Option	Software	Web	DCS004A71	Monitors and controls the air conditioning system using the Internet and Web browser application on a PC.
Communication Line	*2 Interface for use in BACnet®			DMS502A71	Interface unit to allow communications between VRV and BMS. Operation and monitoring of air-conditioning systems through BACnet® communications.
	Optional DIII board			DAM411A1	Expansion kit, installed on DMS502A71, to provide 3 more DIII-NET communication ports. Not usable independently.
	Optional Di board			DAM412A1	Expansion kit, installed on DMS502A71, to provide 16 more wattmeter pulse input points. Not usable independently.
	*3 Interface for use in LON WORKS®			DMS504B71	Interface unit to allow communications between VRV and BMS. Operation and monitoring of air-conditioning systems through LON WORKS® communication.
Contact/Analog signal	Unification adaptor for computerized control			DCS302A72	Interface between the central monitoring board and central control units
	Wiring adaptor for electrical appendices (2)			KRP4A71-74	To control the group of indoor units collectively, which are connected by the transmission wiring of remote controller.
	External control adaptor for outdoor unit (Must be installed on indoor units.)			DTA104A53, 61, 62	Cooling/Heating mode change over. Demand control and Low noise control are available between the plural outdoor units.

### Note:

\*1.BACnet® is a registered trademark of American Society of Heating, Refrigerating, and Air-Conditioning Engineers (ASHRAE).

\*2.LON WORKS® is a registered trademark of Echelon Corporation.

## 2. Control Devices

### 2.1 BRC1C71 Wired Remote Controller

The optional Remote Controller for indoor units provides versatile system control.

Remote controller wiring for a simplified BRC2A71 Remote Controller is the same as that of the standard BRC1C72 Remote Controller. Because the functions of the simplified remote controller are limited, we recommend using in combination with a central remote controller.

#### 2.1.1 Appearance and Functions



- Large liquid crystal screen displays complete operating status.
- Digital display allows temperature settings in 1°F units.
- Operation start/stop can be programmed using timer for periods up to 72 hours.
- Thermostat sensor provides room temperature control for optimum comfort.
- Microcomputer monitors room temperature and preset temperature, automatically selecting cool/heat operation. (VRV System Heat Recovery Series only)
- Use any indoor remote controller to select cool, heat, or fan mode without using the main cool/heat selection switch.
- Continuous monitoring of 40 possible malfunctions with self-diagnosing capability for messaging you immediately in the event of a problem.
- Allows a variety of field settings from remote controller.

#### 2.1.2 Example of Control by Remote Controller

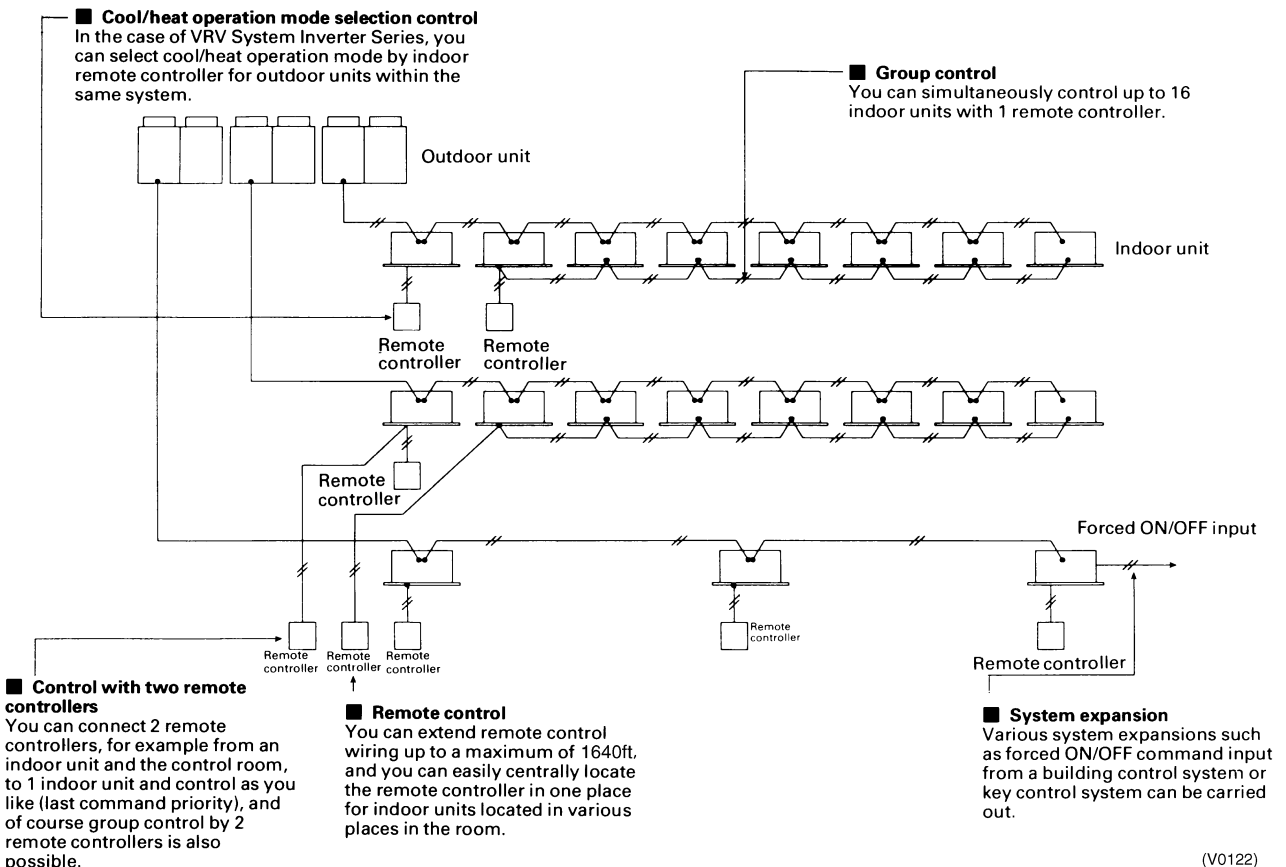

(V0122)

### 2.1.3 Two Remote Controllers

#### 1 indoor unit is controlled by 2 remote controllers from 2 separate locations

This is a convenient system for operating an office indoor unit from the reception area, or an indoor unit from a local or remote location.

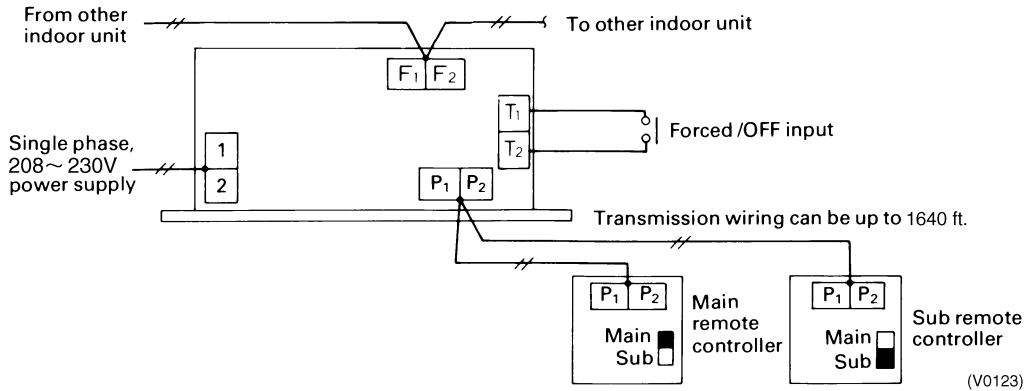

- Operation mode of the indoor unit is last command priority.
- Remove the front panel of the remote controller and set the main/sub changeover switch on the PC board to **MAIN** for the main remote controller, and to sub **SUB** for the sub remote controller.

**Note:**

The remote controller is equipped with a thermostat sensor. If the main and sub remote controllers are mounted in separate rooms, set the main remote controller so that its thermostat sensor is not used so that it does not determine the temperature for all rooms.

### 2.1.4 Group Control

#### Simultaneous control of up to 16 units with a single remote controller:

The following diagram illustrates a convenient system for simultaneous control of several indoor units on a wide, single floor.

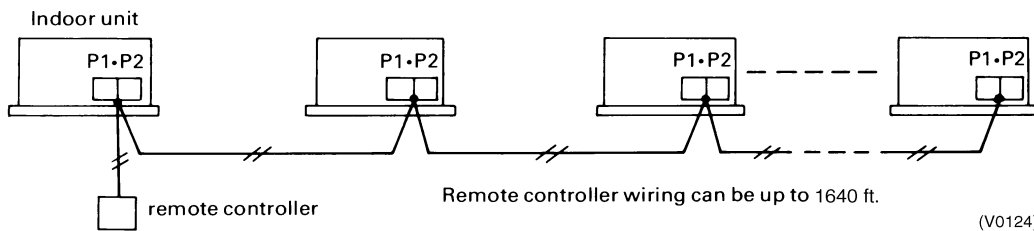









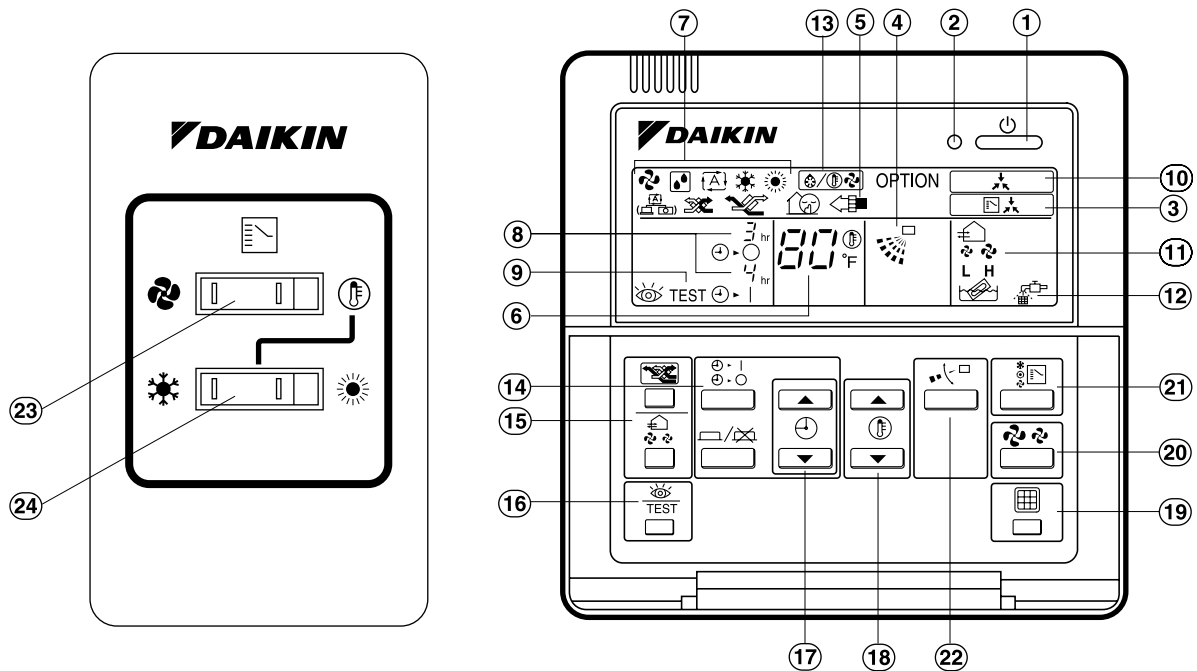





- Wiring for remote controller group control has no polarity, therefore P<sub>1</sub> and P<sub>2</sub> can be switched.
- All indoor units within the group have the same setting, and each indoor unit is controlled individually by its own built-in thermostat.
- Because automatic address is used, an address does not have to be set by remote controller for group control.

**Note:**

Only remote controller wiring is shown.

## 2.1.5 Remote Controller and Changeover Switch: Name and Function of Each Switch and Display



1. **ON/OFF button**  
Press to start; press again to stop system.
2. **Operation lamp red**  
The lamp lights during operation.
3. **Display**  **indicates changeover under control**  
It is impossible to changeover heat/cool with the remote controller when this icon is displayed.
4. **Display**  **indicates air flow flap**  
Refer to the chapter **Operation procedure - Adjusting the air flow direction**.
5. **Display**  **OPTION indicates ventilation/air cleaning**
6. Shows that optional accessories total heat exchange and/or air cleaning unit are operating. **Display**  **80°F set temperature**  
Shows the temperature set.
7. **Display** "  " "  " "  " "  " **operation mode**  
. Shows current operation mode.
8. **Display**  **programmed time**  
Shows the programmed time of the system start or stop.
9. **Display**  **TEST indicates inspection/test operation**
10. When the inspection/test operation button is pressed, the display indicates current mode. **Display**  **indicates under centralized control**  
Indicates system is under centralized control. This is not a standard specification.
11. **Display**  **indicates fan speed**  
Indicates fan speed selected.
12. **Display**  **indicates it is time to clean air filter**  
Refer to the indoor unit manual.
13. **Display**  **indicates defrost/hot start**  
Refer to the chapter **Operation procedure - Explanation of heating operation**.
14. **Timer mode start/stop button**  
Refer to the chapter **Operation procedure - Programming start and stop of the system with timer**. Timer on/off button  
Refer to the chapter **Operation procedure - Programming start and stop of the system with timer**.
15. **Inspection/test operation button**  
Only used by qualified service persons for maintenance purposes.
16. **Programming time button**  
Program start and/or stop time.
17. **Temperature setting button**  
Set the desired temperature.
18. **Filter sign reset button**

Refer to the indoor unit manual.

**19. Fan speed control button**

Select the fan speed.



**20. Operation mode selector button**

Select the operation mode. o



**21. Air flow direction adjust button**

Refer to the chapter *Operation procedure - Adjusting the air flow direction.*

**22. Fan only/air conditioning selector switch**

Set the switch to  for fan only operation or to  for heating or cooling operation.

**23. Cool/heat changeover switch**

Set the switch to  for cooling or to  for heating operation.

**NOTE:**

- Unlike actual operation, all indicators are simultaneously displayed in Figure 1 in order to illustrate the many available options.
- If the filter sign lamp lights up, clean the air filter as explained in the indoor unit manual. After cleaning and reinstalling the air filter, press the filter-sign reset button on the remote controller and the sign deactivates.

## 2.1.6 Installation

### 1. Remove the upper part of remote controller.

Insert minus screwdriver into the slots in the lower part of remote controller (2 places), and remove the upper part of remote controller.

The P C board is mounted in the upper part of remote controller. Be careful not to damage the board with the minus screwdriver.

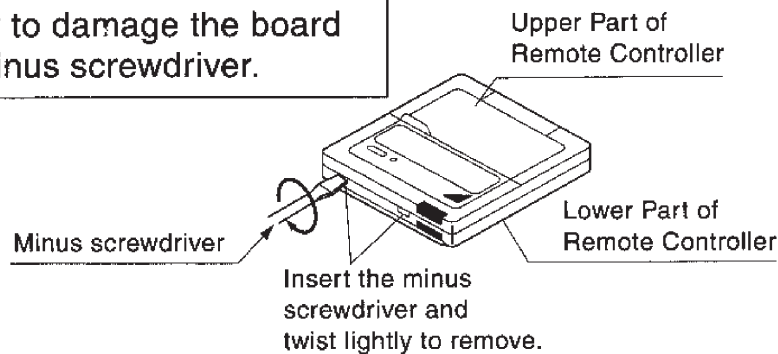

### 2. Fasten the remote controller.

- ① For exposed mounting, fasten with the included wood screws (2).
- ② For flush-mounting, fasten with the included machine screws (2).

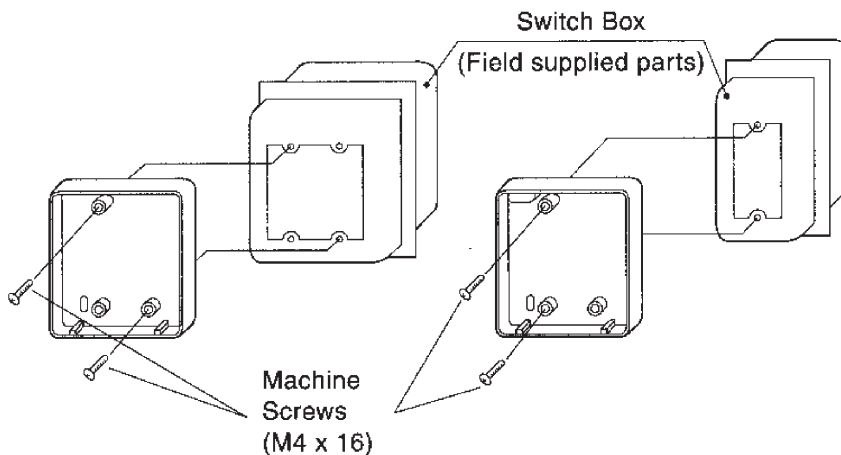
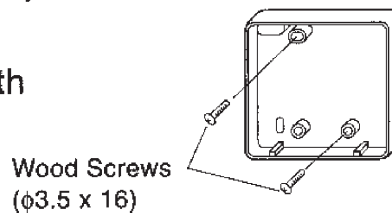

For the field supplied switch box.

### NOTE

Choose the flattest place possible for the mounting surface. Be careful not to distort the shape of the lower part of remote controller by over-tightening the mounting screws.



### 3. Wire the indoor unit.

Connect the terminals on top of the upper part of remote controller (P1, P2), and the terminals of the indoor unit (P1, P2). (P1 and P2 do not have polarity.)

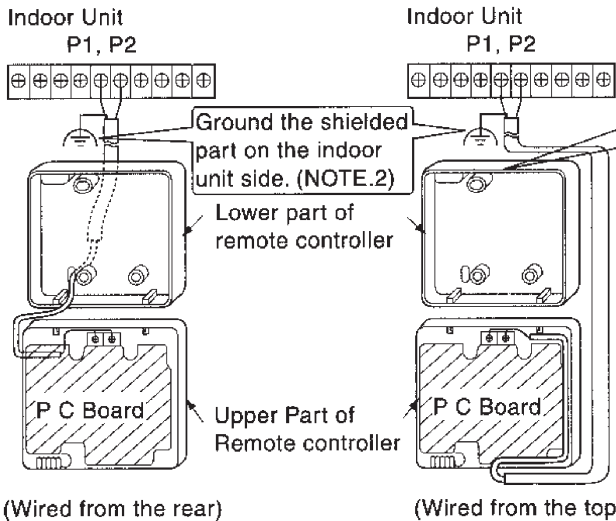

**NOTE**  
When wiring, run the wiring away from the power supply wiring in order to avoid receiving electric noise (external noise).

Notch the part for the wiring to pass through with nippers, etc.

#### Wiring Specifications

Wiring Type	Sheathed vinyl code or cable (2 wire) (NOTE.2)
Size	18 – 2AWG

**NOTE)** 1. Peel the shield and sheath for the part that is to pass through the inside of the remote controller case, as shown in the figure below.

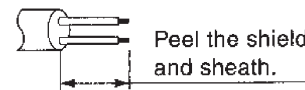

2. Shield wire (2 wire) can be used for remote controller wiring, but it must confirm to EMC (Electromagnetic Compatibility) (Australian regulation).

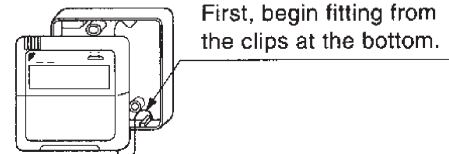

### 4. Reattach the upper part of remote controller.

Be careful not to pinch the wiring when attaching.

#### NOTE

1. The switch box and wiring for connection are not included.
2. Do not directly touch the PC board with your hand.

**If controlling one indoor unit with two remote controllers**

Change the MAIN/SUB changeover switch setting as described below.

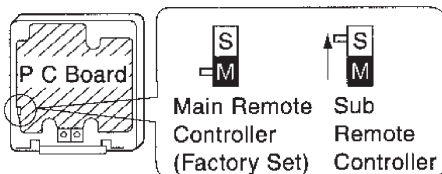

Set one remote controller to "main," and the other to "sub."

#### NOTE

- If controlling with one remote controller, be sure to set it to "main."
- Set the remote controller before turning power supply on.

**"88" is displayed for about one minute when the power supply is turned on, and the remote controller cannot be operated in some cases.**

### 2.1.7 Field Setting Wired Remote Controller BRC1C71

If optional accessories are mounted on the indoor unit, its settings may have to be changed. Refer to the instruction manual for each setting.

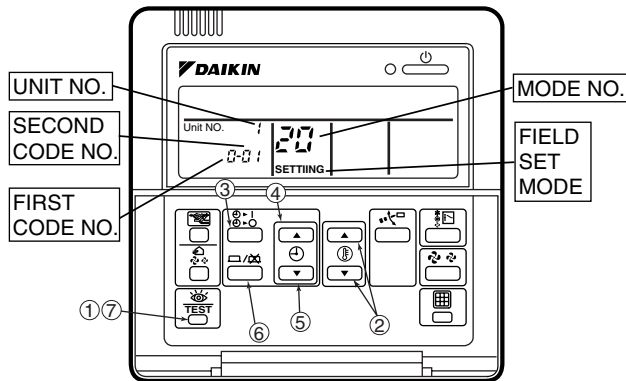

2P068938

**Procedure**

1. When in the normal mode, press the button for a minimum of four seconds, and the FIELD SET MODE is entered.
2. Select the desired MODE NO. with the button (2).
3. During group control, when setting by each indoor unit (mode No. 20, 21 and 23 have been selected), push the button (3) and select the INDOOR UNIT NO to be set. This operation is unnecessary when setting by group.
4. Push the upper button (4) and select FIRST CODE NO.
5. Push the lower button (5) and select the SECOND CODE NO.
6. Push the button (6) once and the present settings are SET.
7. Push the button (7) for about one second to return to the NORMAL MODE.

Example: If set for group setting and the time to clean air filter is set to: **FILTER CONTAMINATION-HEAVY**, you should set MODE NO. to [10], FIRST CODE NO. to [0] and SECOND CODE NO. [02].

**Field Setting Contents and Code No.**

Mode No. Note)1	FIRST CODE No.	Description of Settings	SECOND CODE NO. Note)4							
			01		02		03		04	
10(20)	0	Filter Contamination-Heavy/ Light: Setting for display time to clean air filter. Time alert to clean air filter is cut in half when heavy filter contamination.	UltraLong-Life Type		Approx. 10,000 hours		Approx. 5,000 hours		—	
		Long-Life Type		Approx. 2,500 hours		Approx. 1,250 hours		—		
		Standard Type		Approx. 200 hours		Approx. 100 hours		—		
	1	Long-life or Standard filter type: Setting of filter indication time. Change setting to Ultralong-life filter if one is installed	Long-Life Filter		Ultra-Long- Life Filter		—		—	
2	Thermostat Sensor in Remote Controller	Use		Not Use		—		—		
3	Display Time to Clean Air Filter Calculation (Set when filter sign is not to be displayed	Display		Do not Display		—		—		
12(22)	0	Optional accessories output selection field selection of output for adaptor for wiring	Indoor Unit Turned ON by Thermostat		—		Operation Output		Malfunction Output	
	1	ON/OFF Input from Outside: Set when ON/OFF is to be controlled from outside.	Forced Off		ON/OFF Control		External Protection Device		—	
	2	Thermostat Differential Changeover: Set when remote sensor is to be used.  FXFQ only	1°C		0.5°C		—		—	
	4	Automatic mode differential: Automatic temperature differential setting for VRV system heat recovery series cool/heat	01 : 0	02 : 1	03 : 2	04 : 3	05 : 4	06 : 5	07 : 6	08 : 7
	5	Power failure automatic reset: Auto Restart	Not equipped		Equipped		—		—	
13(23)	1	Selection of Air Flow Direction: Set when a blocking pad kit has been installed  FXFQ only	F (4 directions)		T (3 directions)		W (2 directions)		—	
	4	Field set airflow position setting	Draft Prevention		Standard		Ceiling Soiling Prevention		—	
	5	Field set fan speed selection: Fan speed control by air discharge outlet for phase control	Standard		Optional Accessory 1		Optional Accessory 2		—	

**Notes:**

1. Setting is carried out in the group mode. If the mode number inside the parentheses is selected, indoor units can also be set individually.
2. The SECOND CODE number is set in the bold bordered display  when shipped from the factory.
3. Mode not displayed if the indoor unit is not equipped with that function.
4. When returning to the normal mode, [SE] may be displayed in the LCD in order for the remote controller to initialize itself.

**2.1.8 Dimensions**  
**■ BRC1C71**

• REMOTE CONTROLLER DIMENSIONS

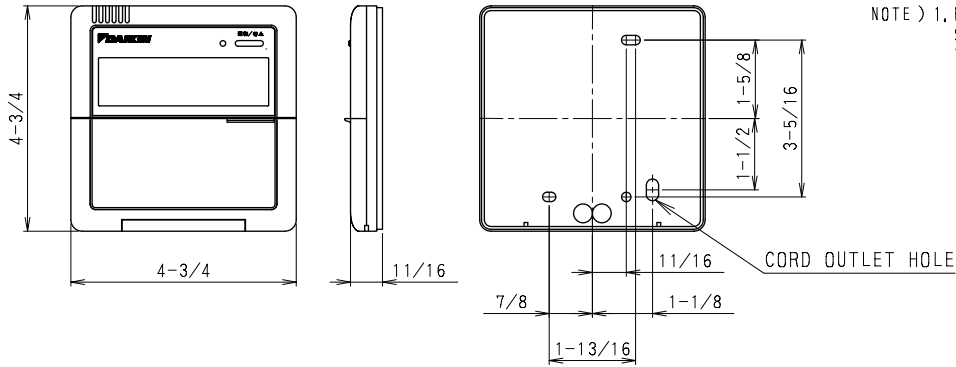

NOTE ) 1. REMOTE CONTROLLER CORD AND STAPLE ARE NOT ATTACHED, THEY ARE FIELD SUPPLIED PARTS.

• SPECIFICATIONS OF CORD

TYPE	VINYL CORD WITH SHEATH OR CABLE (INSULATED THICKNESS: 18-2 AWG OR MORE)
SIZE	AWG16 OR AWG18
TOTAL LENGTH	1640ft.

• INSTALLATION METHOD

Ⓐ EXPOSED BODY, EXPOSED CORD

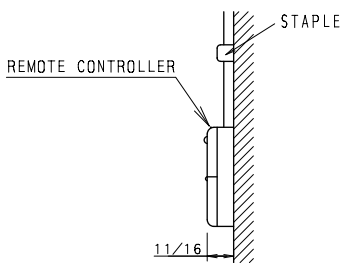

Ⓑ EXPOSED BODY, EMBEDDED CORD

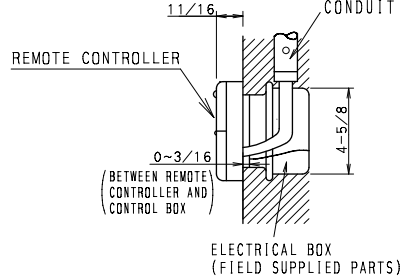

Ⓒ EXPOSED BODY, EMBEDDED CODE

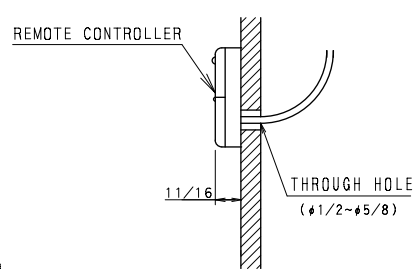

3D045753

## 2.2 BRC4C / 7C / 7E Wireless Remote Controller / Receiver

### ■ BRC7C812

• REMOTE CONTROLLER DIMENSIONS

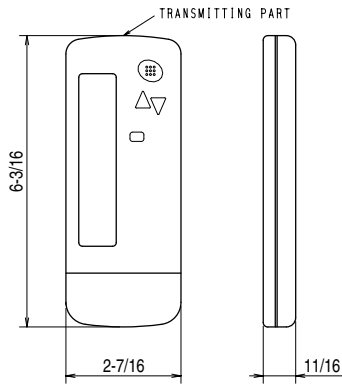

• REMOTE CONTROLLER HOLDER INSTALLATION PROCEDURE  
<INSTALLATION TO WALL SURFACE>

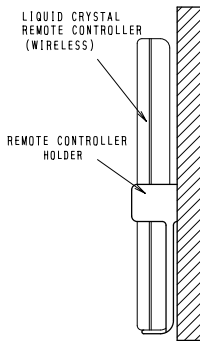

• RECEIVER INSTALLATION PROCEDURE

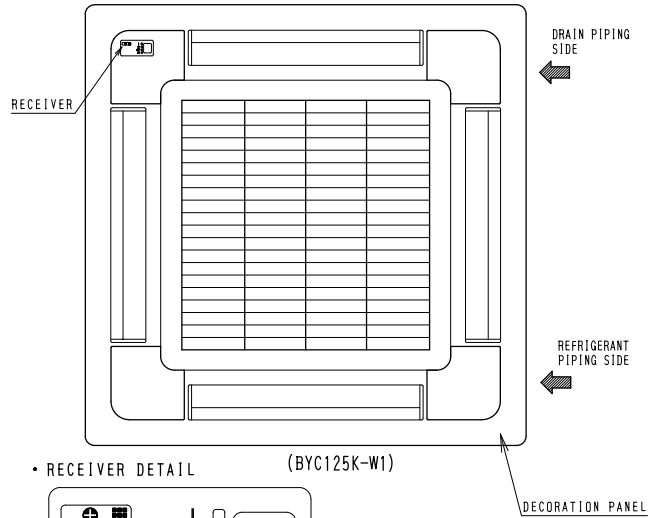

• RECEIVER DETAIL (BYC125K-W1)

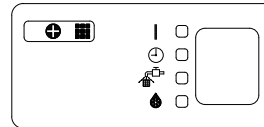

• WIRELESS REMOTE CONTROLLER KIT FOR EACH DECORATION PANEL

WIRELESS REMOTE CONTROLLER KIT	DECORATION PANEL
BRC7C812	BYC125K-W1

C:3D005912D

### ■ BRC4C82

• REMOTE CONTROLLER DIMENSIONS

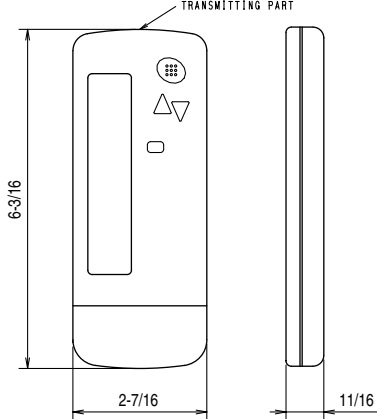

• REMOTE CONTROLLER HOLDER INSTALLATION PROCEDURE  
<INSTALLATION TO WALL SURFACE>

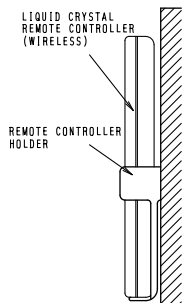

• RECEIVER DETAIL

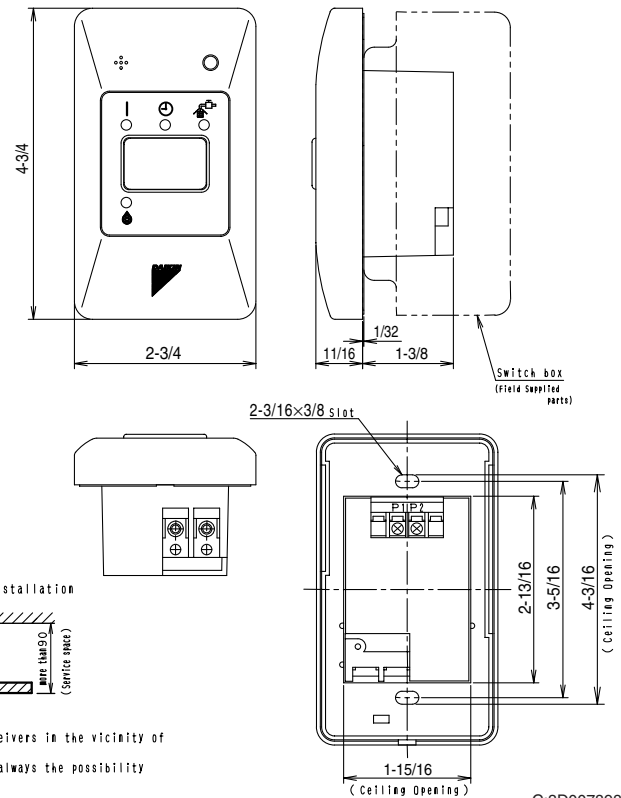

• Service space for ceiling installation

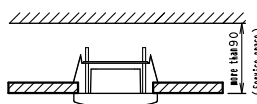

**NOTE** Do not install more than 3 receivers in the vicinity of one another. With 4 or more units, there is always the possibility of malfunction.

C:3D007898A

■ BRC7E83

• REMOTE CONTROLLER DIMENSIONS

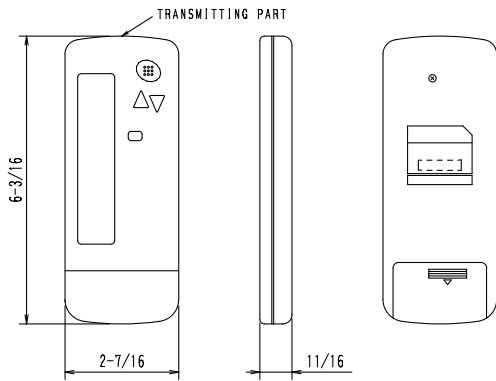

• RECEIVER INSTALLATION PROCEDURE

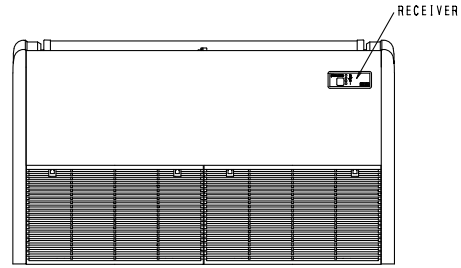

• REMOTE CONTROLLER HOLDER  
INSTALLATION PROCEDURE  
<INSTALLATION TO WALL SURFACE>

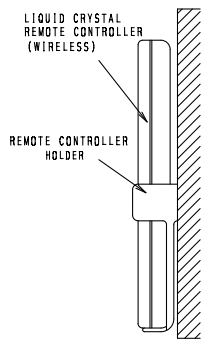

• RECEIVER DETAIL

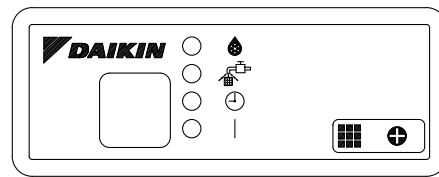

3D049336

■ BRC7E818

• REMOTE CONTROLLER DIMENSIONS

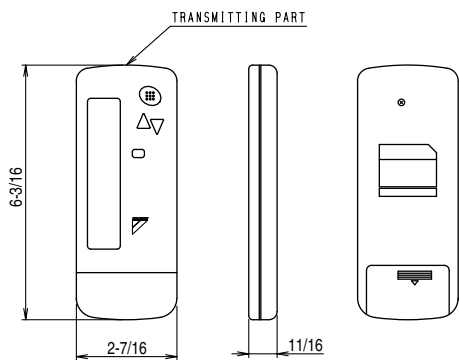

• RECEIVER INSTALLATION PROCEDURE

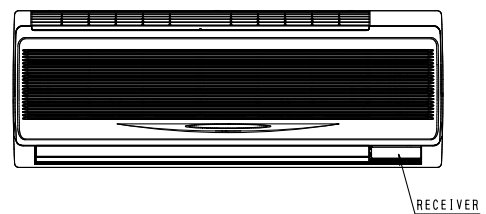

• REMOTE CONTROLLER HOLDER  
INSTALLATION PROCEDURE  
<INSTALLATION TO WALL SURFACE>

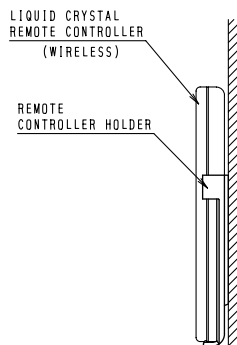

• RECEIVER DETAIL

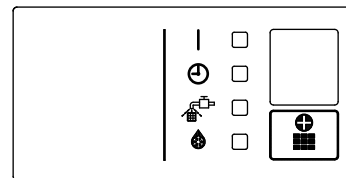

• WIRELESS REMOTE CONTROLLER KIT







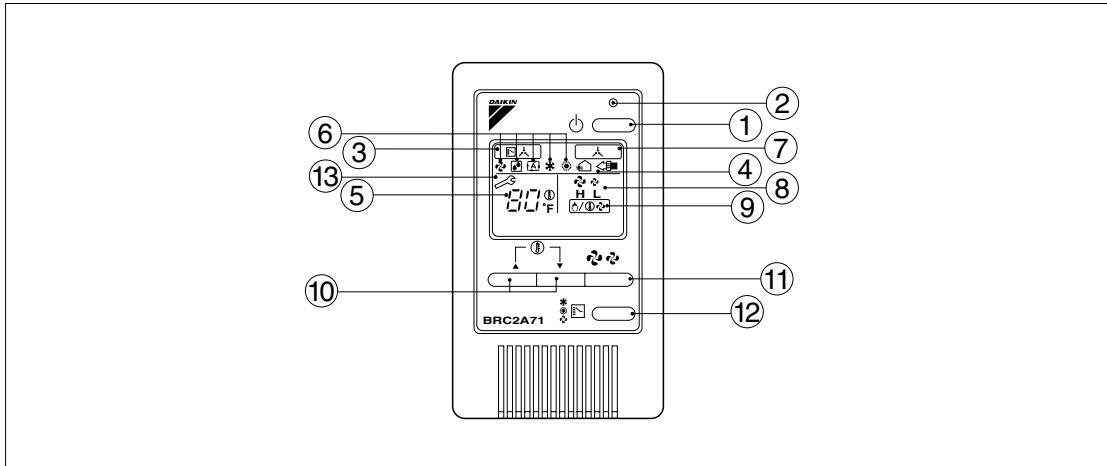



WIRELESS REMOTE CONTROLLER KIT	INDOOR UNIT
BRC7E818	FXAQ~MVJU

C:3D034905B

**2.3 BRC2A71 Simplified Remote Controller**  
**2.3.1 Name and Function**



**REMOTE CONTROLLER: NAME AND FUNCTION OF EACH SWITCH AND DISPLAY**

①	<b>ON/OFF BUTTON</b>	⑦	<b>DISPLAY “” (UNDER CENTRALIZED CONTROL)</b>
	Press the button and the system will start. Press the button again and the system will stop.		When this display shows, the system is UNDER CENTRALIZED CONTROL. (This is not a standard specification)
②	<b>OPERATION LAMP (RED)</b>	⑧	<b>DISPLAY “” (FAN SPEED)</b>
	The lamp lights up during operation. Blinks in case of stop due to malfunction.		This display shows the fan speed: HIGH or LOW.
③	<b>DISPLAY “” (CHANGEOVER UNDER CONTROL)</b>	⑨	<b>DISPLAY “” (DEFROST / HOT START)</b>
	It is impossible to changeover heating/cooling with the remote controller when it shows this display. (As for details, see “SETTING OF MASTER REMOTE CONTROLLER” in the installation manual attached to the indoor unit.)		Indicates that defrost or hot start (during which the fan is stopped till the temperature of air supply rises enough at the start of a heating operation) is in progress.
④	<b>DISPLAY “” (VENTILATION/AIR)</b>	⑩	<b>TEMPERATURE SETTING BUTTON</b>
	This display shows that the total heat exchanger and the air cleaning unit are in operation. (These are optional accessories).		Use this button for SETTING TEMPERATURE of the thermostat. ▲ ; Each press raises the set temperature by 1 F. ▼ ; Each press lowers the set temperature by 1 F. The variable temperature range is between 60 F and 90 F.
⑤	<b>DISPLAY “” (SET TEMPERATURE)</b>	⑪	<b>FAN SPEED CONTROL BUTTON</b>
	This display shows the set temperature. Only given during a cooling or heating operation.		Press this button to select the fan speed, HIGH or LOW, of your choice.
⑥	<b>DISPLAY “” (OPERATION MODE)</b>	⑫	<b>OPERATION MODE SELECTOR BUTTON</b>
	This display shows current OPERATION MODE. “  ” is not available with outdoor units specially designed for cooling only. “  ” is reserved only for outdoor units capable of heat recovery.		Press this button to select OPERATION MODE.
⑬		⑬	<b>DISPLAY “” (MALFUNCTION)</b>
			Indicates malfunction and blinks if the unit stops operating due to malfunction. (As for details, see “TROUBLE SHOOTING” in the operation manual attached to the outdoor unit.)

For the sake of explanation, all indications are shown in the figure above contrary to actual running situations.

3P146204

### 2.3.2 Installation

#### 1. Remove the upper part of remote controller.

Insert a minus screwdriver into the slot between the upper and the lower part of remote controller.

**NOTE**

- Do not directly touch the PC board with your hand.

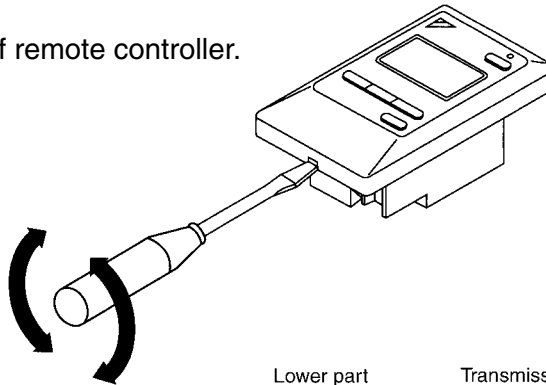

#### 2. Wire the indoor unit.

Connect terminals P1 and P2 on the rear of the lower part of remote controller to terminals P1 and P2 on the indoor unit. (Terminals P1 and P2 have no polarity.)

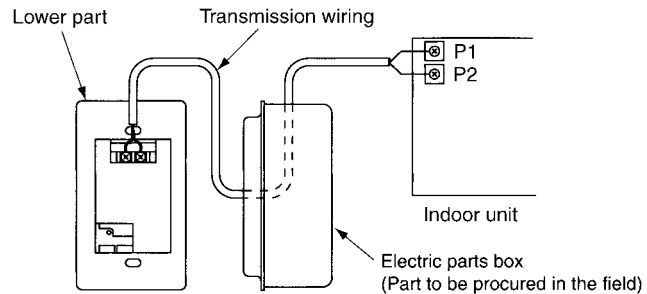

**NOTES**

- The electric parts box and wiring for connection are not included.
- When wiring, run the wiring away the power supply wiring in order to avoid receiving electric noise (external noise).
- When wiring, refer to the wiring diagram of indoor unit (attached to indoor unit) as well.

**WIRING SPECIFICATION**

Wiring type	Sheathed wire (2 wire)
Size	AWG18 or AWG16

#### 3. Fasten the remote controller.

Attach the lower part of remote controller to the electric parts box (part to be procured in the field).

**NOTE**

Choose the flattest place possible for the mounting surface. Be careful not to distort the shape of the lower part of remote controller by over-tightening the mounting screws.

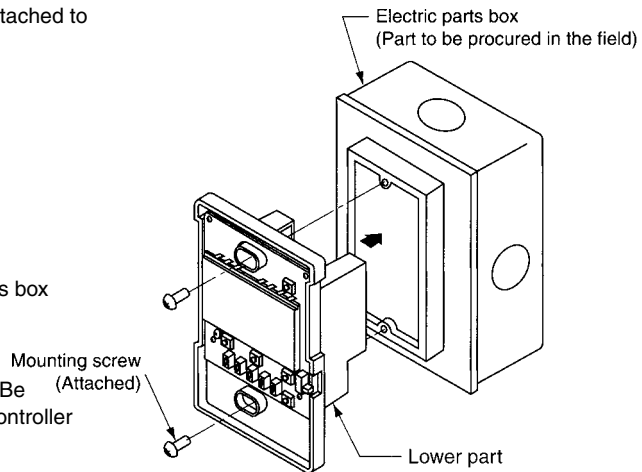

For the electric parts box to be procured in the field, use optional accessories KJB111A.

#### 4. Initial setting

Change the MAIN/SUB changeover switch setting as described below.  
If controlling one indoor unit with two remote controllers, set one remote controller to "MAIN." and the other to "SUB."



Main Remote Controller  
(Factory Set)



Sub Remote Controller

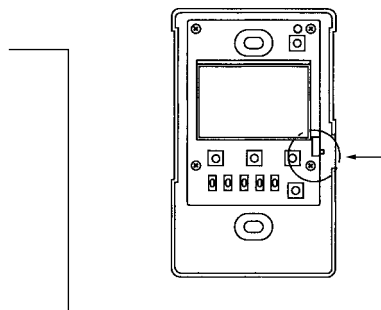

**NOTES**

- If controlling with one remote controller, be sure to set it to "MAIN."
- Set the remote controller before turning power supply on.

"88" is displayed for about one minute when the power supply is turned on, and the remote controller cannot be operated in some cases.

**5. Reattach the upper part of remote controller.**

**NOTE**

1. Do not directly touch the PC board with your hand.

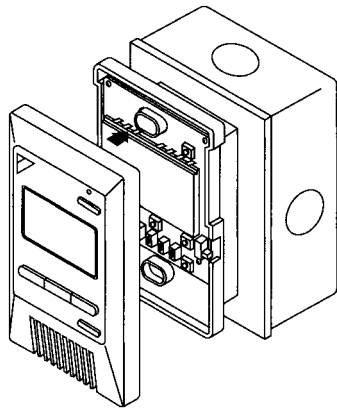

3P146205-2

**2.3.3 Dimensions**

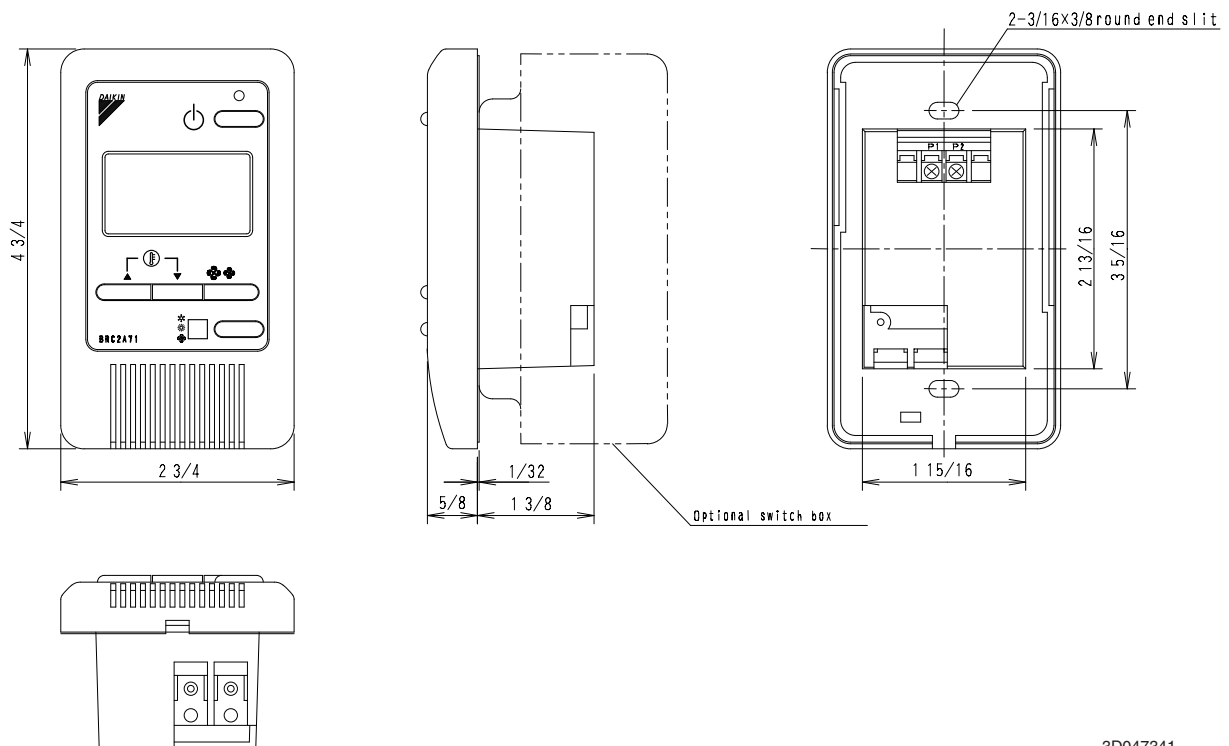

3D047341



## 2.4 DCS302C71 Central Remote Controller

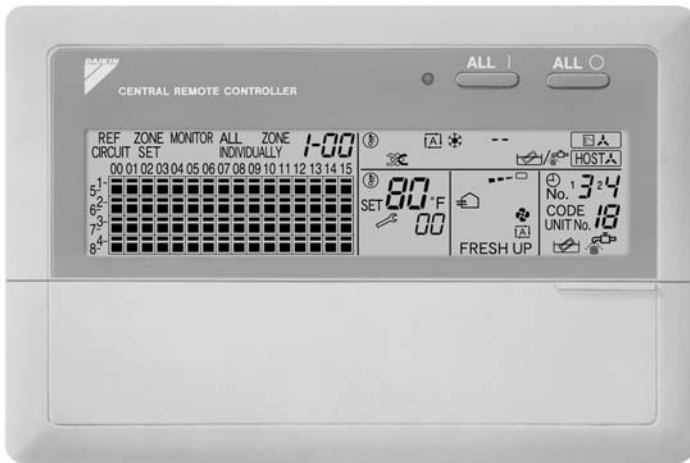

- You can connect up to 64 groups of indoor units (maximum 128 units) and operate or monitor ON/OFF, temperature settings, and so forth, by individual zone or together.
- Up to 2 units are connectable within 1 system and up to 4 units in case of the double central control mode.
- Executes zone control for up to 64 zones and is designed for operation efficiency.
- Error contents are displayed in code so that maintenance and inspections can be conducted immediately.
- 1 schedule timer and up to 4 unified on/off controllers can be connected to a single unit, and you can easily extend the central control system according to building size and purpose.
- Applicable wiring methods include bus and star in addition to series wiring.

### 2.4.1 System Configuration

#### System Outline

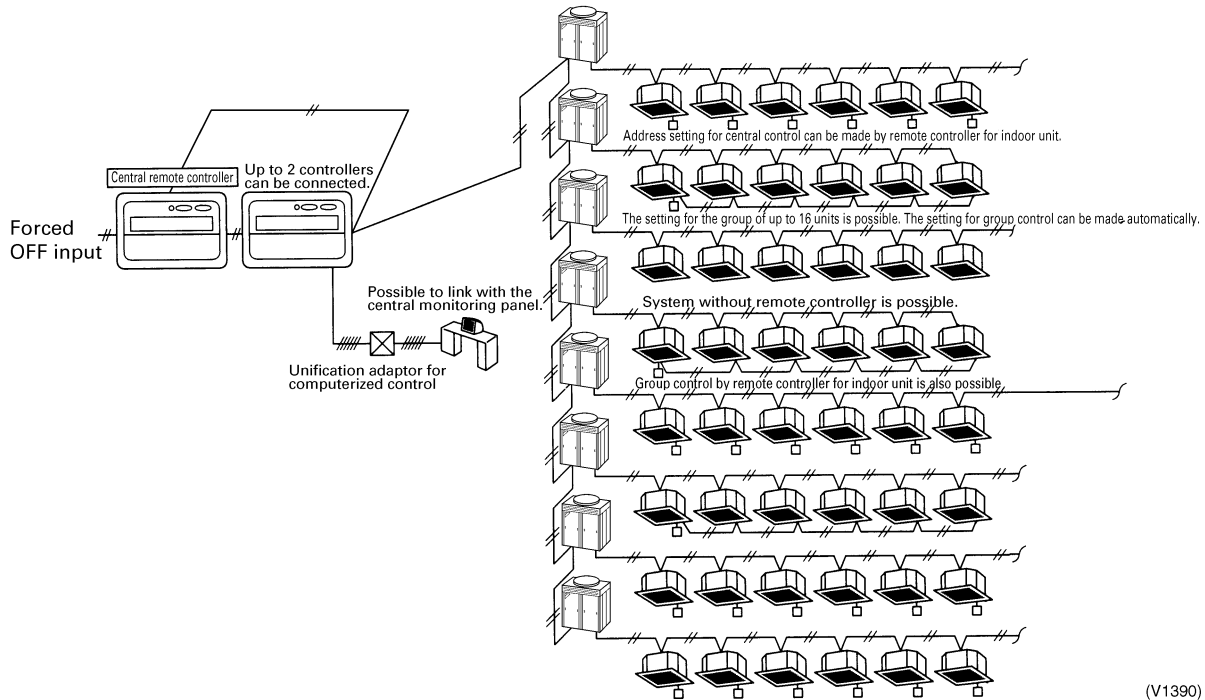

(V1390)

**System Configuration for Group / Zone Control**

■ **Group control**

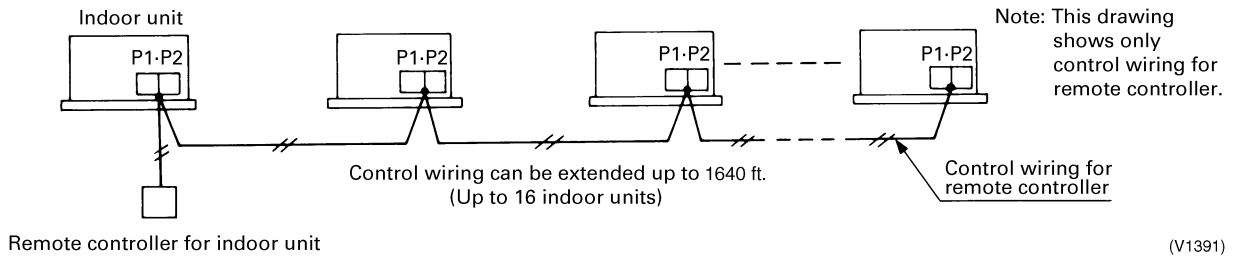

- Group control configuration allows all indoor units to be connected by the same remote controller connected to terminal P1 and P2, and all the units in group have the same setting and the same operation.
- The group of indoor units is controlled by the master indoor unit's remote controller.
- The maximum number of indoor units in one group is 16 units.

■ **Zone control**

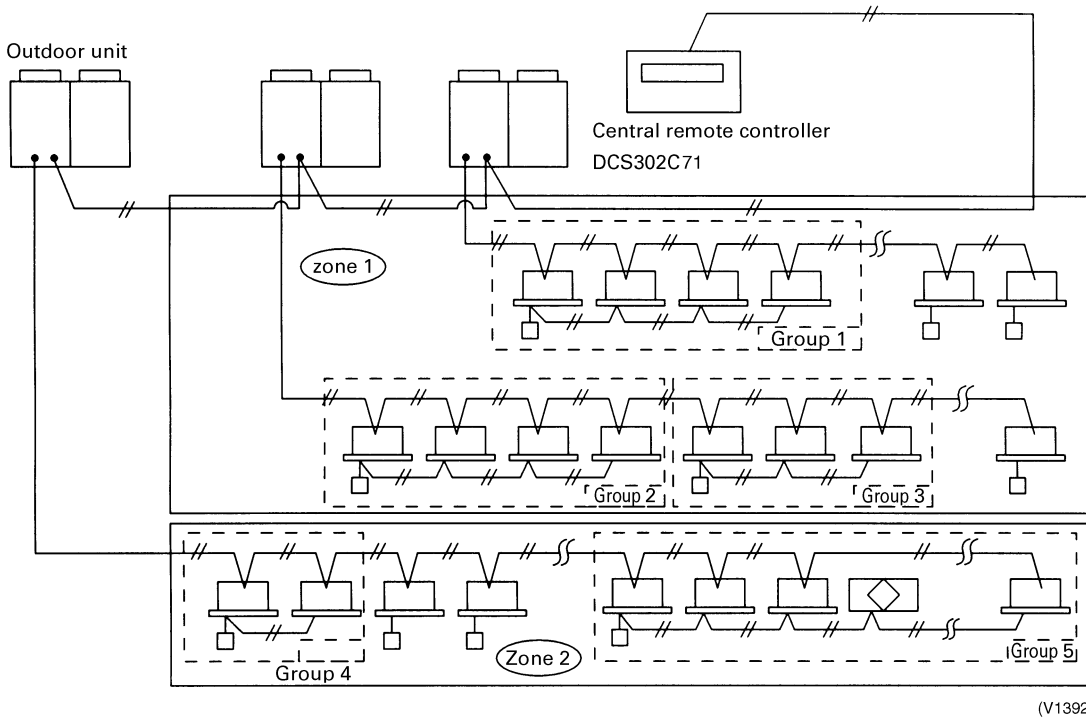

- A zone is a group of indoor units interconnected to terminal F1 and F2 utilizing one central remote controller that applies the same settings to all units.
- The zone control of the indoor unit is operated by the central remote controller.
- 1 to 64 zones can be controlled by the central remote controller.
- You can set up to 64 groups in one zone.
- Up to 16 units can be set in one group, and up to 64 groups (up to 128 units) can be connected.

**System Configuration (Control by 2 central remote controllers)**

- Up to 128 indoor units can be connected in one system.
- 2 or 4 central remote controllers are required. It is possible to control the same unit from 2 locations.
- Up to 16 unified ON/OFF controllers can be connected using 8 controllers covering 2 locations.
- One scheduling timer can be connected.

**Notes:**

1. Electrical power should be supplied to each central remote controller. (Single phase 100~240V)
2. When you control by 2 central remote controllers, be sure to set SS3 by the initial setting.

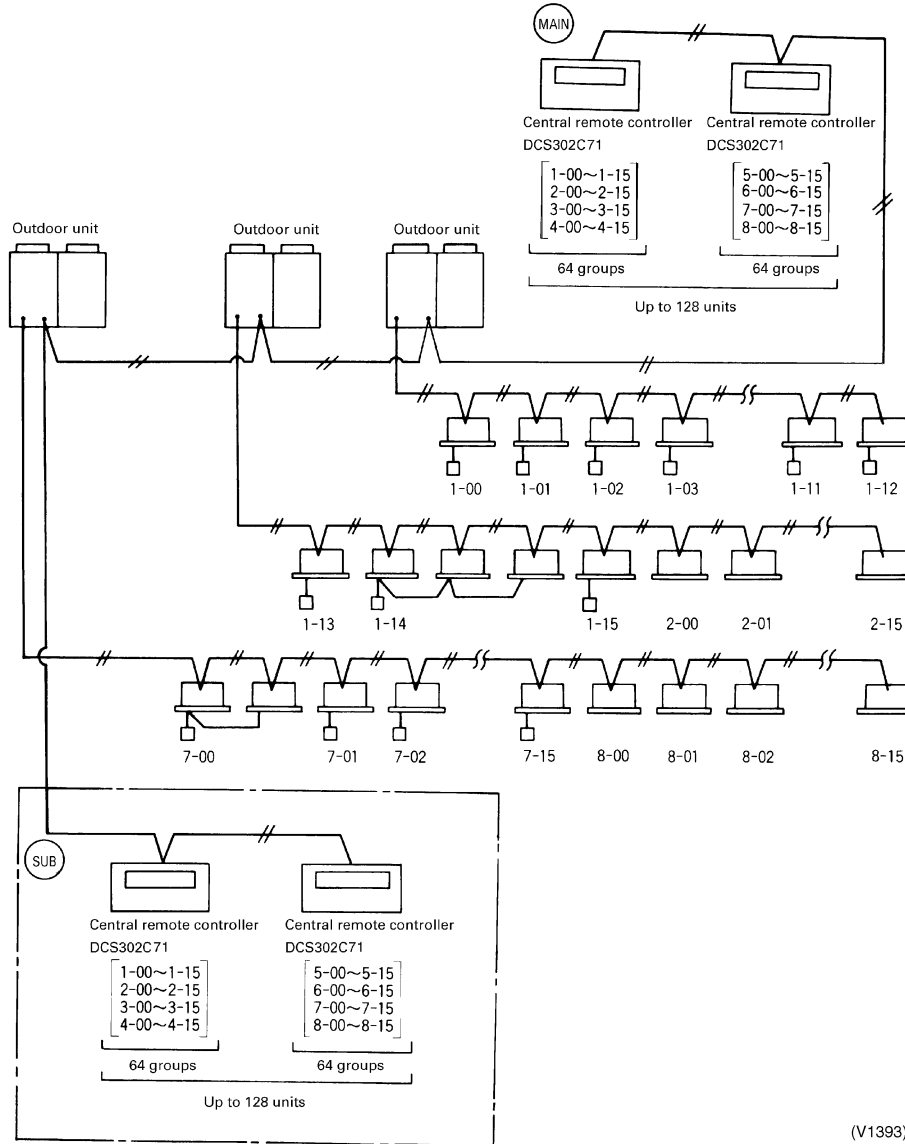

(V1393)

(★) When you control by 2 central remote controllers, the last entered setting takes priority.

**Note:**

The **Operation Code Setting** cannot be made by the sub side. Be sure to set by the main side.

## 2.4.2 Specifications / Dimensions

### Specifications

	DCS302C71
Power supply voltage / frequency	AC100~240V ±10% 50/60Hz
Power consumption	Max. 8W
Setting data backup	Non-volatile memory preserves data semi-permanently
Effects of instantaneous power failure	No effect for 20 mili-sec. or less
Forced OFF input Operation on the local side cannot be carried out during forced OFF input.	<ul style="list-style-type: none"> <li>■ No-voltage normal open contact</li> <li>■ Micro-current contact capable of handling 16VDC and approx. 10mA.</li> <li>■ Max. 492 ft cable length</li> </ul>
Power supply for schedule timer	Power can be supplied to schedule timer. (Max. 1 unit)
Operating ambient temperature / humidity condition	-5~40°C, 95% RH or less (no condensation)
Size (width × height × depth)	7 1/8×4 3/4×2 9/16 exposed portion of front panel: 5/8 (Unit: Inch)
Machine Weight (Mass)	Approx. 0.95 lbs

### Dimensions

#### DCS302C71

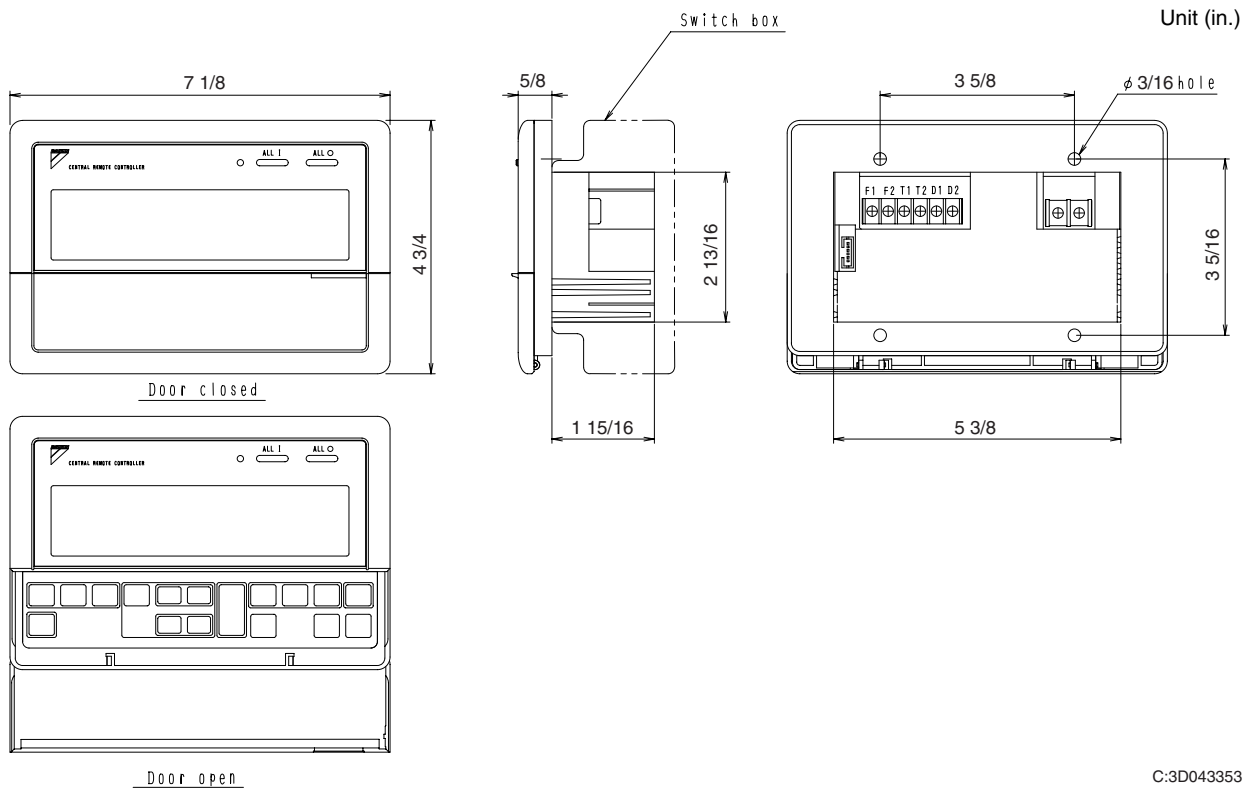

### 2.4.3 Names and Functions of Operating Part

■ Display part DISPLAY (OPERATION MODE) Displays operating state.

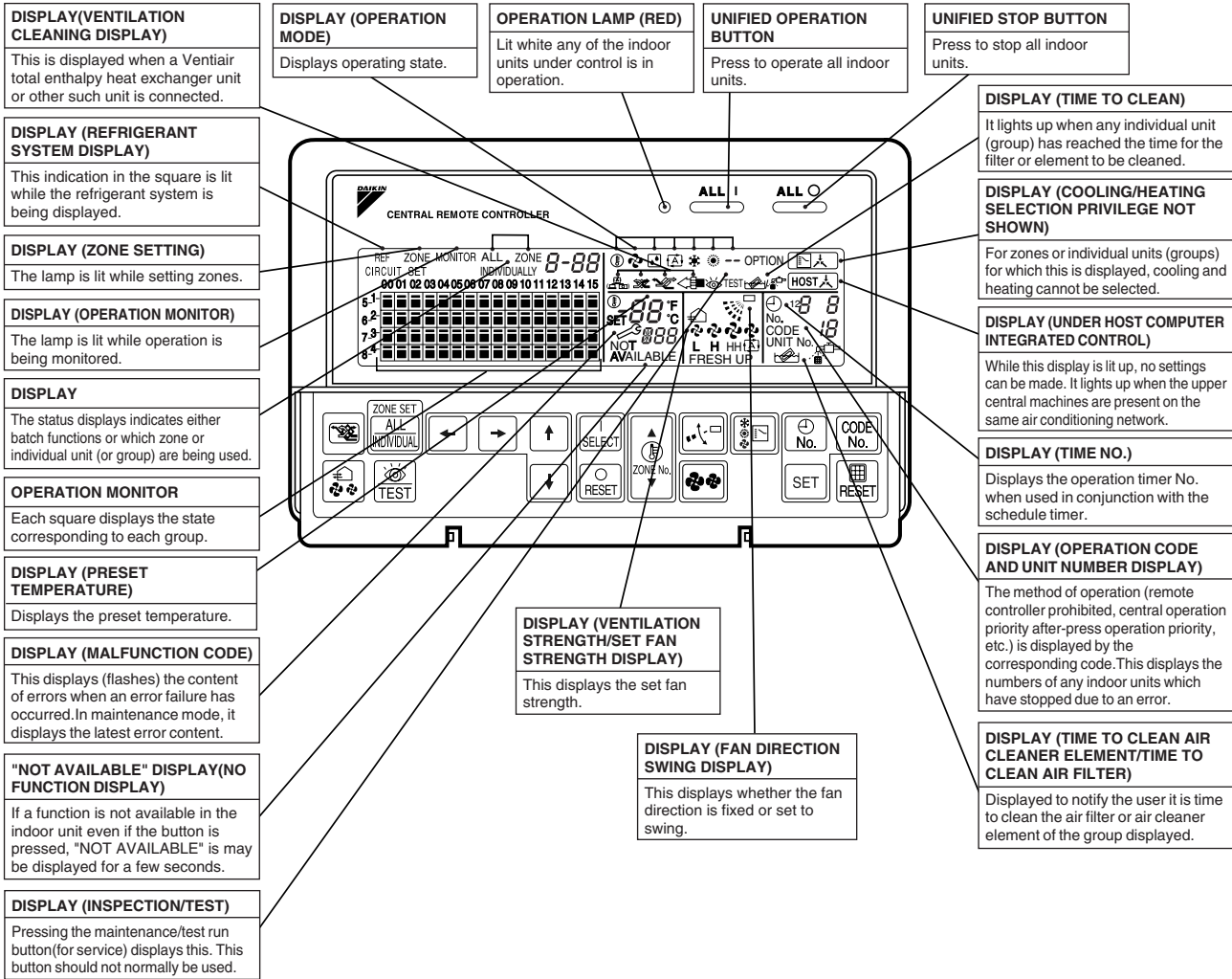

■ Control Section

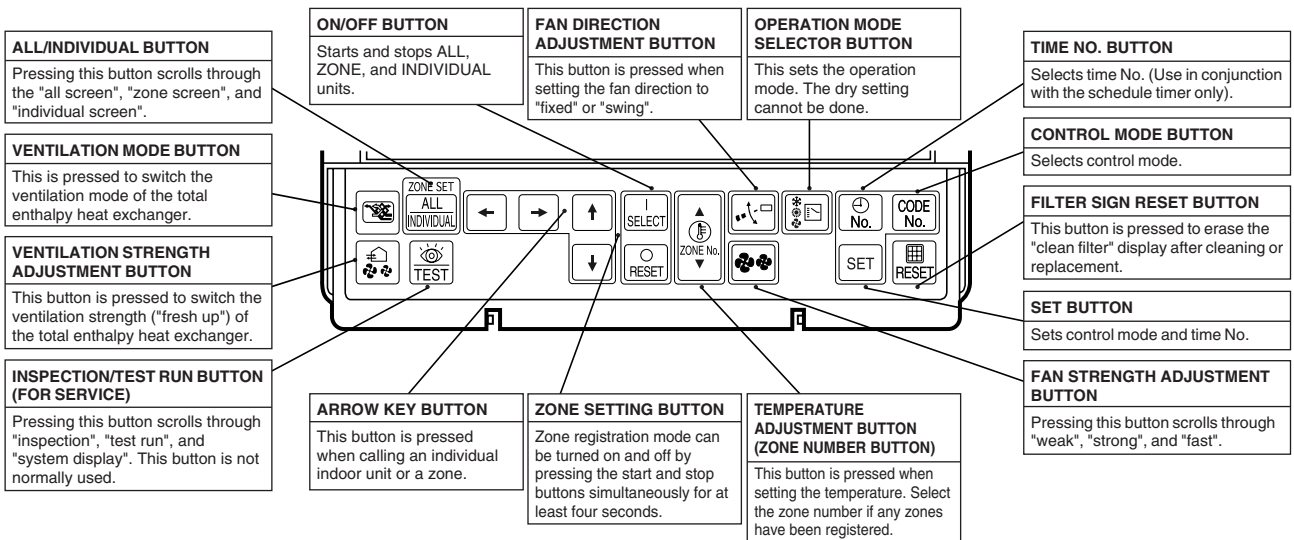

## 2.4.4 Description of Functions

### Individual Screen, All Screen, Zone Screen

This controller can perform operations in the following screens:

- **INDIVIDUAL SCREEN** for performing group operations.
- **ALL SCREEN** for performing operations for all units at once.
- **ZONE SCREEN** for performing zone operations.

### Basic functions

Function	Descriptions of outline
Individual/Zone control	Up to 64 groups (Max. 128 units and max. 16 units per group) of indoor units and HRV units can be controlled by individually or by zone.
Unified ON/OFF	ON/OFF can be set for each zone, and can be controlled simultaneously for entire system by push button or by remote controller.
Malfunction code display	The status of each group is always displayed, such as ON/OFF, error, etc. If the error occurs, it displays the malfunction code and type of error with the self-diagnosis function.
Connection of unification adaptor for computerized control	By connecting the optional unification adaptor for computerized control, it can be linked with the central monitoring panel by contact signal, which enables you to operate ON/OFF simultaneously, and monitor the operating status.
Remote control acceptance/rejection	It is possible to restrict the function of local remote controller: Only ON operation rejection, or ON/OFF operation rejection.
2 central controllers	By connecting two central remote controllers, the same air-conditioner can be controlled from 2 locations: By tenant or administration office.

### Zone control functions

Function	Descriptions of outline
Zone control	The zone function is a function to control one or more groups of airconditioners, and operation settings, such as ON/OFF, can be made by zone.
Up to 64 zones	Up to 64 zones (64 groups for each zone) can be set. However, the group setting spreading over the plural zone cannot be set.
Zone register	When the power is supplied the first time, each group is registered in its respective zone. You can register several groups in the same zone by switch, to enable simultaneous operation of the units immediately. The temperature setting is also controlled by zone simultaneously.
Zone setting	By adding the zone setting function (Zone "0") from the central remote controller, you can make one setting for all the zones registered by single operation.
ON/OFF control of zone	For example, if there are three groups in one room and if you register these three groups as one zone, you can operate all three simultaneously by single operation (ON/OFF, temperature setting, and so forth). You can also operate each group individually by local remote controller.
Maintaining zone setting	Even if the power is turned off, the zone configurations set are maintained semi-permanently and saved in non-volatile memory.
Cool/Heat changeover by zone	The cool/heat changeover can be made by zone if you establish a master group for Cool/Heat changeover for that zone.
Batch operation	The same setup is possible at one operation to all the groups registered on the "All" screen.
No local remote controller	Even without a local remote controller, you can still perform the same batch operation. However, in this case, each air-conditioning unit consists counts as group.
Combination with other controllers	You can combine operations with a unified ON/OFF controller and a schedule timer. Refer to the system configuration for details.
Connection to central monitoring panel	You can combine with an Interface for use in BAC net <sup>®</sup> and a data station in order to connect to the central monitoring panel. A parallel interface can also be connected.

**Cool/Heat changeover and settings**

Function	Descriptions of outline
Possible control	The operation mode of the outdoor unit can be changed by the local remote controller or by the central remote controller. For test operation, change setting of cool/heat selector switch of the outdoor unit.
Remote controller acceptance/rejection	You can set acceptance/rejection on the central remote controller with the local remote controller.
<b>NOT AVAILABLE display</b>	Pressing a button for an unavailable function in the indoor unite activates the <b>NOT AVAILABLE</b> display.

**NOTE:**

Cool/heat Mode-setting capability for the Indoor Unit Remote Controller:

The outdoor unit's operation mode of fan, dry, auto (available only with Heat Recovery units), cooling, or heating can be selected using the indoor unit's designated primary remote controller that is connected to the outdoor unit. The settings chosen for the primary remote controller determine the settings for the remaining controllers. . For the Heat Recovery series, if 2 or more indoor units are connected to one BS unit, you must set the fan, dry, auto, cooling, or heating operation on the primary remote controller connected to the BS unit.

Only remote controller designated for settings can change the operation mode.

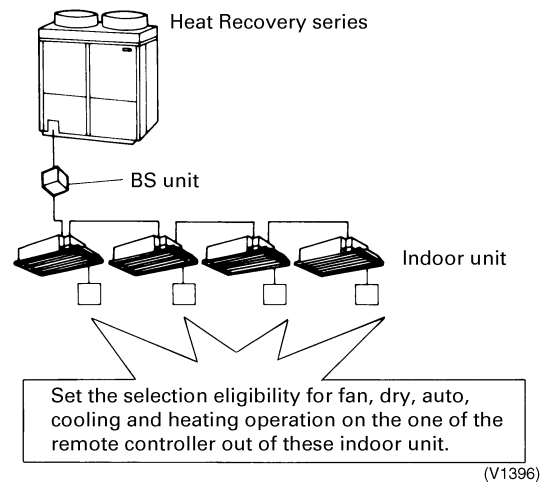
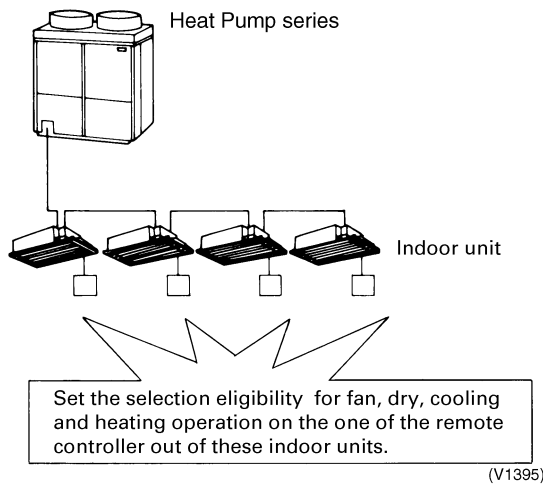

■ **Setting method for cool/heat**

**1. Preparation**

- When turning on the power the first time, the **CHANGEOVER UNDER CONTROL** sign blinks.

Use the following procedure to set operation mode:

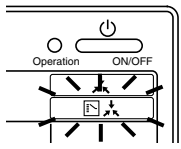

1

Continue to push **Operation switch** for about 4 seconds.  sign blinks on all the indoor units connected to the outdoor unit or BS unit.



**2. Selection Eligibility Setting**

2

Push **Operation switch** of the remote controller, which you want to set the selection eligibility. This completes the setting procedure. Cool/heat selection eligibility is set for that remote controller, and  sign goes off.  still blinks on all other remote controllers.

**3. Operation mode changeover**

3

Push **Operation switch** of remote controller having the selection eligibility (The remote controller not displaying  sign) several times to select the desired operation mode. [Fan], [Dry], [Auto](only for Heat Recovery series),[Cooling] and[Heating] mode are selected each time you push the [Operation switch]. Operation mode of other remote controllers, which has no selection eligibility, is also switched automatically.

(V1397)

■ **Description of operation and its function:**

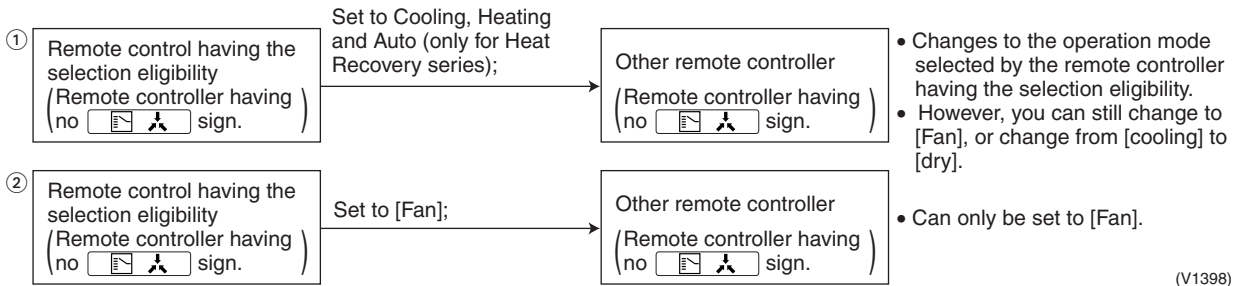

(V1398)

Note: Selection modes are also available on the wireless remote controller. It is not possible to set **DRY** mode with the Central Remote Controller.



## Control with Two Central Remote Controllers

The central remote control equipment is the newly designed **C** type that allows 2 central remote controllers to be connected as shown in the following example:

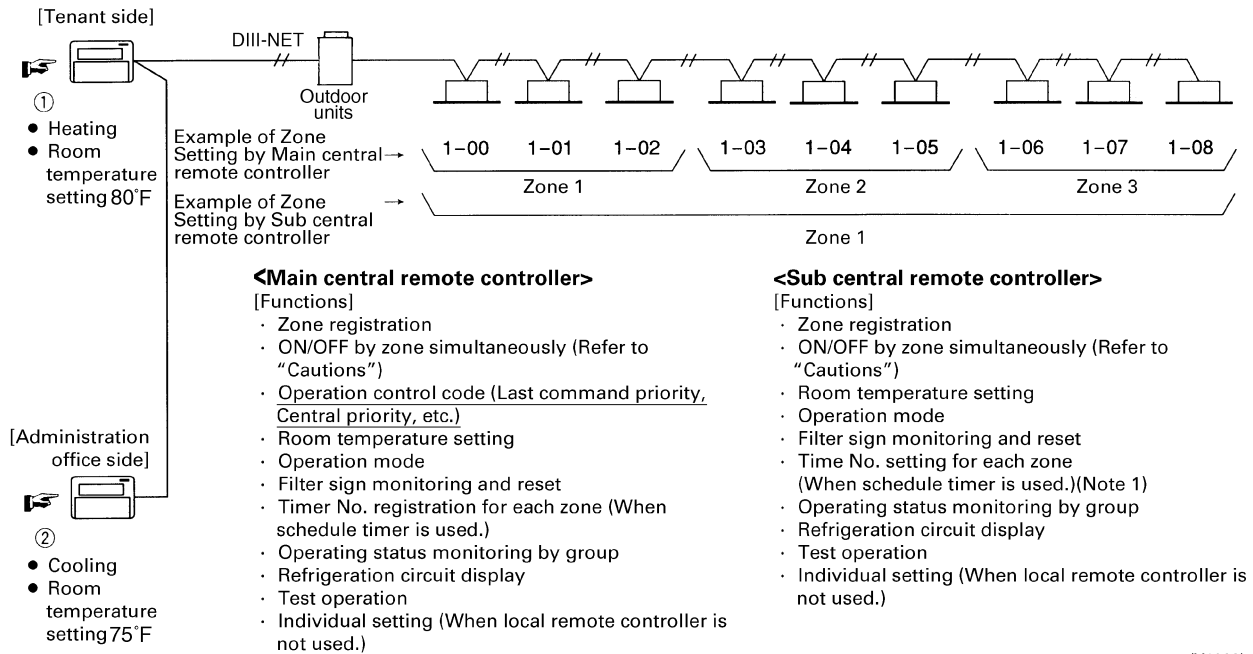

### Note:

If a timer number is registered by the sub central remote controller, the timer mode for the local remote controller (mode no. 8, 9, 18, and 19) for the same units set by the Main remote controller are deactivated.

### Explanation of the above figure

If you operate the central remote controller in the sequence of ① and ②, the indoor unit is set for cooling / temperature setting 75°F.

However, the display of zone setting of the master remote controller remains at heating / temperature setting at 80°F.

### Cautions

- Operation code cannot be set by the sub central remote controller.
- Combined zone operation can only be set by zone registration of the main central remote controller.
- Both main and sub central remote controller are operated by the most recent command for the functions other than the above.

The display on the central remote controller cannot be changed by other controllers. On the display for the group, you can monitor the present operation status.

**Sequential Start**

Operation command from central control equipment

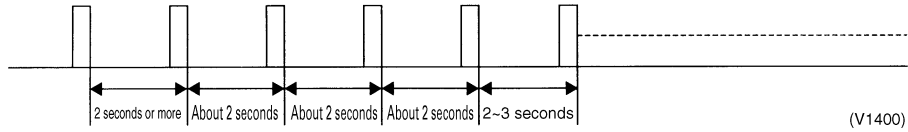

Each unit operates in sequence. For example, if you set simultaneous operation by the central remote controller for groups 1-00 ~ 4-15, and 5-00 ~ 8-15, two outdoor units start simultaneously.

**Registering Zone**

It is possible to set multiple groups as one zone and control each zone separately. No zones are registered when the unit is shipped from the factory. Zone registration can be done in the individual screen, all screens, or the zone screen.

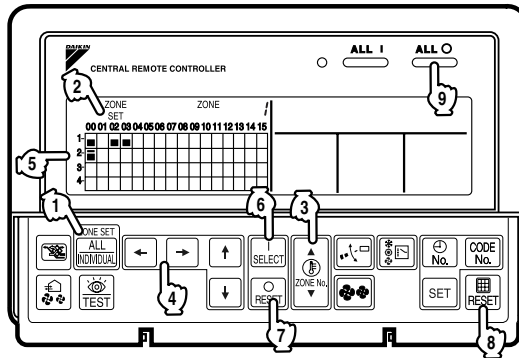

**Registration**

1. **Pressing the ALL/INDIVIDUAL button for four seconds.** Displays ZONE SET. Zone Number 1 is displayed, and if there are any groups already registered in the displayed zone, a  will light up on the operation monitor.
2. **Select the Zone Number to be registered using the ZONE NUMBER button.** Keeping the button pressed down moves it rapidly.
3. **Press the TEST button to the group you wish to register using the arrow keys.** Keeping the button pressed down moves it rapidly.
4. **Press the SELECT button to register that group to the zone.** The  display lights up on all the selected units. **Pressing the RESET button removes the group from that zone, and the display goes off.** Repeat steps 3 and 4 until all the units you wish to register to the zone have been added.

	ZONE		ZONE															
	SET		00	01	02	03	04	05	06	07	08	09	10	11	12	13	14	15
1-	<input checked="" type="checkbox"/>	<input checked="" type="checkbox"/>	<input checked="" type="checkbox"/>															
2-	<input checked="" type="checkbox"/>																	
3-																		
4-																		

In this example, a screen is shown with units 1-00, 1-02, 1-03, and 2-00 registered to Zone Number 1.

5. Repeat steps 2 to 4 to register to the next zone.
6. Once zone registration is complete, press the ALL/INDIVIDUAL button to turn off ZONE SET display and return to the individual screen. The display returns to the normal screen if nothing is done for one minute when in zone registration mode.

**NOTE:**

- It is impossible to register one group to several different zones. If this is done, the last zone registered is effective.

**Batch deletion of zone registration**

1. Pressing the ALL  for at least four seconds while  pressing the FILTER SIGN RESET button when  ZONE SET is displayed deletes all zone registrations.

**Zone setting**

To set all zones for uniform operation, the central remote controller should display **Zone 0** with the following modes selected:

- Operation mode
- Control mode
- Room temperature setting
- Time Clock No.

**NOT AVAILABLE Display**

If a particular function is not available for the unit, **NOT AVAILABLE** displays for approximately two seconds when you attempt to access that function.

If another unavailable function button is pushed, the **NOT AVAILABLE** display will continue an additional two seconds.

**Monitor in a zone unit**

Operating and monitoring the system in a group or by individual zones is enabled from the DCS302C71. Monitoring in a zone is accessed by using an indoor unit with a lower address within the zone as the Main Indoor Unit.

The following options are displayed for monitoring zones:

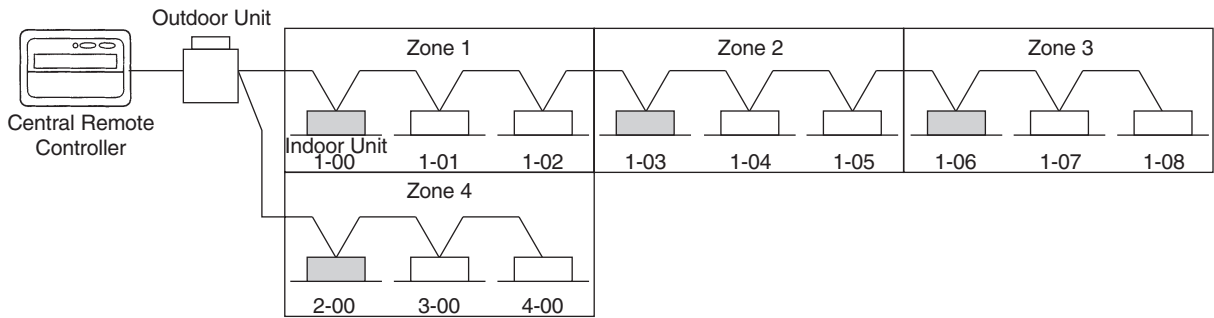

	Main Indoor Unit	Operation Code Timer No.	Temp. Display	Operation Mode
Zone 1	1-00	1-00	1-00	1-00
Zone 2	1-03	1-03	1-03	1-03
Zone 3	1-06	1-06	1-07	1-07
Zone 4	2-00	2-00	N/A	N/A

If the system is operated on the Zone screen, the same setting is reflected for all indoor units registered with that zone.

On the Zone screen, ventilation mode can be only monitored, not changed. In order to change to ventilation mode, be sure to use the Individual screen.

On the Batch screen, operating and monitoring is enabled to allow monitoring an indoor unit with a lower address within the scope of control.

### Changing the Fan Direction and Fan Strength

Changing the fan direction and strength is accessed from the following screen: .

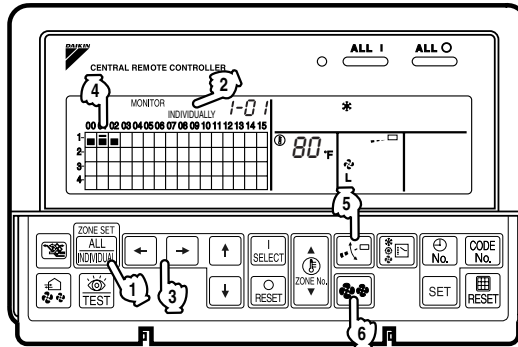

#### Registration

1. Press the **ALL/INDIVIDUAL** button to enter the individual screen.  
The unit opens the individual screen automatically if nothing is done for one minute.
  2. Using the arrow keys, move the to select the units to fan direction adjustment or fan strength adjustment.  
Keeping the button pressed down advances options rapidly.
  3. Press the **FAN DIRECTION ADJUSTMENT** button.  
This sets **FIXED** or **SWING** fan direction.  
 Press the **FAN STRENGTH ADJUSTMENT** button.  
Pressing this button scrolls through , and .
- Depending on the indoor unit, only and may be available.

The functions included in the indoor units may vary. Pressing a button for an unavailable function prompts **NOT AVAILABLE** to display.

### Timer Number Setting

**Only when used with the schedule timer**

Using this together with the schedule timer makes it possible to set on/off function four times a day. Two settings of ON/OFF are possible to one Schedule Timer and two Schedule Timers can be registered into a Central Remote Controller.

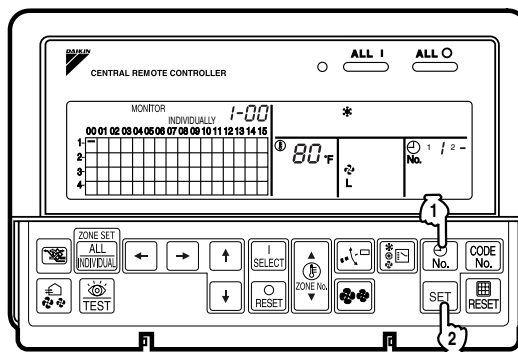

#### Registration

1. Pressing the **TIMER No.** button causes the number set for timer number 1 to blink.  
If no timer setting has been made a dash [-] is displayed. Select the desired timer number by pressing the "TIMER No." button.

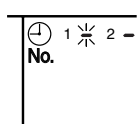

2.  **Once the desired timer number is displayed, press the SET button.**

Press the  **SET** button within 10 seconds after the timer number is displayed.

The display will return to how it was after 10 seconds.

The display for timer number 1 will stop blinking and then timer number 2 will start blinking.

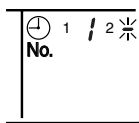

3.  **Select the desired timer number by pressing the TIMER NO. button.**

Once the desired timer number is displayed,  press the **SET** button.

The display for timer number 2 will stop blinking.

The  **No.** display disappears after 3 seconds.

Select [-] instead of a timer number when you do not wish to set a timer number.

It is possible to set only one timer number.

The times for turning the unit(s) on and off twice a day can be set with a single timer number, as shown in the following figure:

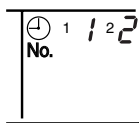

■ **Timer Number Setting**

Group control: select the unit in the individual screen and set the timer number.

Batch control: set the timer numbers for all connected units.

Zone control: set the timer numbers for all zone-registered units.

Call up the zones which you wish to set in the zone screen and set the timer numbers.

- **Since the most recent timer number set takes priority, the last screen setting applies to the connected units.**

**Example 1:**

Setting timer number 1 for unit 1-00 to [1] and timer number 2 to [2] in the individual screen and subsequently setting timer number 1 to "3" and timer number 2 to [4] in the batch screen defaults all timer numbers for all units to the batch setting, so that timer number 1 for unit 1-00 becomes [3] and timer number 2 becomes [4].

**Example 2:**

To prevent leaving units on, timer number 1 is set to [5] in the batch screen.

Setting timer number 1 in zone number 1 to [-] in the zone screen after that will change the timer number for zone number 1, so the setting to prevent leaving the units on will be lost for zone number 1 only.

If a timer number is set incorrectly, re-enter the correct setting in the desired screen.

- **When the timer number on time and off time are set to the same time:**

When the on time and off time are set to the same time for the same timer number, operation does not change.

When the on time and off time are set to the same time for different timer numbers, the off time is given priority.

When setting the timer operation, make sure the scheduled times do not overlap.

## 2.4.5 Wiring Instructions

### Wiring instructions

For control wiring of DIII-NET, you can select from the following 3 types of wiring methods:

#### 1. Series method:

Wiring is connected by a single line from the central controller.

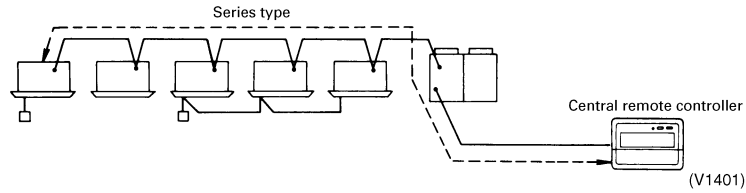

#### 2. Bus method:

Up to 16 branches are possible. Never diverge the sub-branches from the branch line.

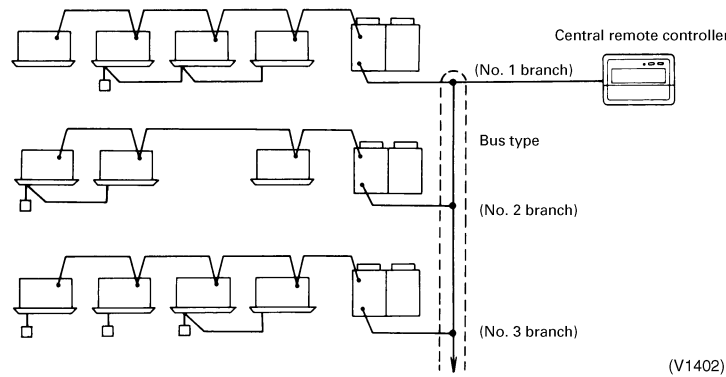

#### 3. Star method:

Up to 16 branches are possible. Never diverge the sub-branches from the branch line.

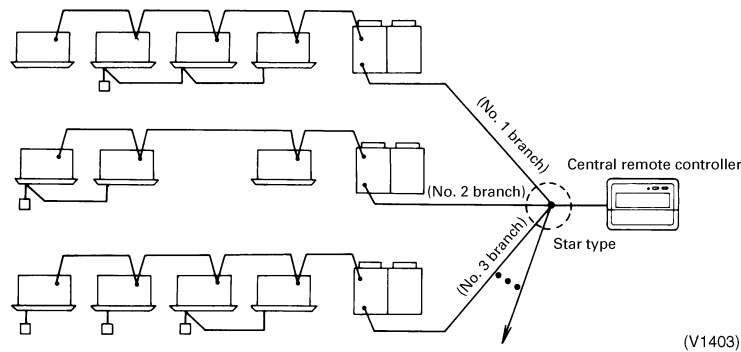

### Specifications of transmission wiring:

Be sure to use 2-conductor, 18 AWG, stranded, non-shielded, copper cable / PVC or vinyl jacket.

#### Length of control wiring:

Between central remote controller and air-conditioner

Maximum extension : 3280 ft, Total length : 6560 ft \*





\* When you have branches, the total length is for all branches combined.

## 2.4.6 Instructions for Initial Setting

### Group No. Setting for Central Control Equipment

Group No. should be set for each group by the remote controller for indoor unit when you operate the system with central remote controller and unified ON/OFF controller. For the same control group, set only one of the units.

#### ■ Remote controller for indoor unit

1. Turn ON the power of the indoor unit and central remote controller. No settings can be made without the power ON.  
(  
Check that the installation and electrical wiring are correct before turning the power supply ON.  
When the power supply is turned ON, all LCD appear once and the unit may not accept the operation for about one minute with the display of [88].
2. While in the normal mode, hold down the  button for a minimum of 4 seconds.  
The remote controller will enter the FIELD SET MODE.
3. Select the MODE No. [00] with the  button.
4. Use the  button to select the group No. for each group.  
(Group numbers increase in the order of 1-00, 1-01, ... 1-15, 2-00, ... 4-15.)
5. Press  to set the selected group No.
6. Press  to return to the NORMAL MODE.

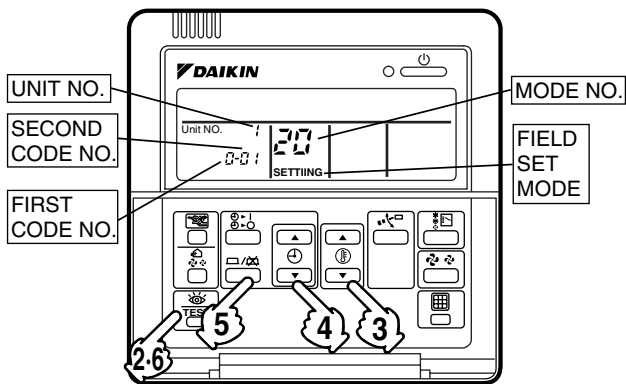

(V1910)

#### ■ Simplified remote controller

- Group No. setting by simplified remote controller.
  1. Remove the cover of remote controller.
  2. While in normal mode, press the [BS6] BUTTON (field set) to enter the FIELD SET MODE.
  3. Select the mode No. [00] with [BS2] BUTTON (temperature setting ▲) and [BS3] BUTTON (temperature setting ▼).
  4. Select the group No. with [BS9] BUTTON (set A) and [BS10] BUTTON (set B). (Group Numbers increase in the order of 1-00, 1-01.....1-15, 2-00,.....4-15. However, the unified ON/OFF controller displays only group No. set within the range of control.)
  5. Press [BS7] BUTTON (set/cancel) to set group No.
  6. Press [BS6] BUTTON (field set) to return to the NORMAL MODE.

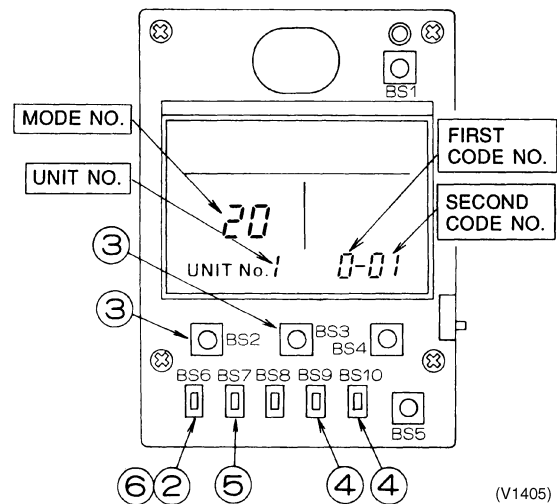

(V1405)

### Cautions

- Even in the systems without remote control, connect the remote controller once to set the Group Number for addressing the central control equipment and after it is set, remove the remote controller.
- When you set the group No., be sure to supply power to the central remote controller, the unified ON/OFF controller, and the indoor unit.

### Example of group setting

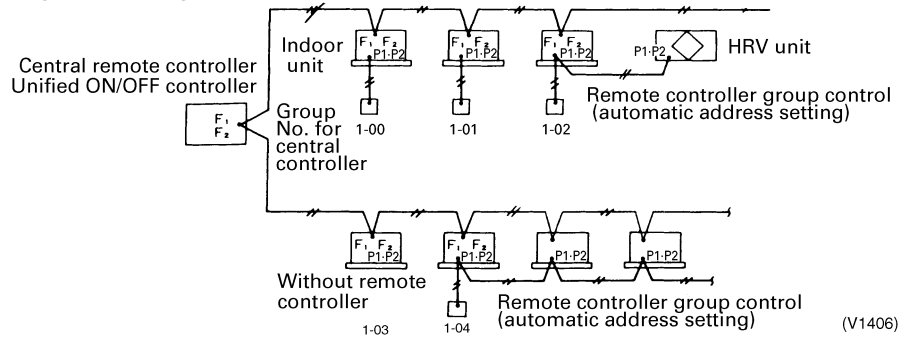

### Cautions

When the power is supplied, all the displays appear at once on the remote controller and then the display changes to [88] for about one minute during which time the remote controller does not function. This is not a malfunction of the remote controller.

## Control Mode Setting(Field Setting)

The control mode defines the function of local remote controllers to handle various types of control and applications. Functions can be defined by conditions and combinations of local remote control operations such as ON/OFF, etc. See table on following page.

Operation can always be conducted from the central remote controller except when connected to the central monitoring panel.

### ■ Description of Control Mode

The following 5 operation control modes and 20 temperature/operation combination modes are set with the remote controller and are displayed by the control mode 0 through 19.

#### Remote Controller Rejection

Choose when you want to turn on/off using only the central remote controller as on/off cannot be conducted by remote controller.)

#### Remote controller Off Only Accepted

Choose when you want to turn on only by the central remote controller, and turn off only by local remote controller.

#### Central Priority

Choose when you want to turn on only by the central remote controller and, during the set time, turn on/off freely by local remote controller.

#### Individual Priority (Last Command Priority)

Choose when you want to turn on/off by both central remote controller and local remote controller.

#### Remote Controller Permission Timer

Choose when you want to turn on/off by local remote controller during set time, but you do not want to start operation from the central remote controller at the programmed time of system start.

#### Note:

The control mode consists of numbers 0 through 19, but only 0 through 9 are usually set.



### 2.4.7 Selection of Control Mode No.

Select whether to accept or reject operations by local remote controller such as Turning on/off, temperature adjustment and operation mode setting respectively, and decide the control mode No. shown in the right side of the following table:

**Example:**

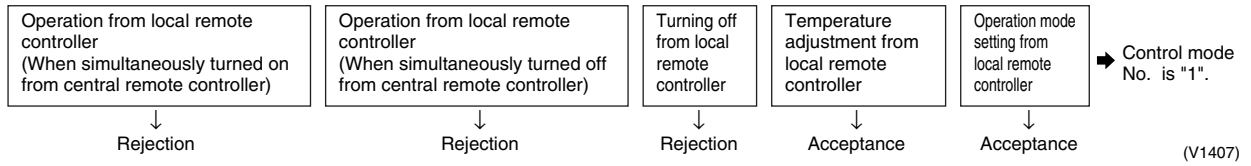

Control mode	Operation from remote controller					Control mode No.
	ON		OFF	Temperature adjustment	Operation mode setting	
	Simultaneous operation, Individual operation and Timer operation is turned ON by central controllers	Simultaneous operation and timer operation is turned OFF by central controllers				
Remote controller rejection	Rejection (example)	Rejection (example)	Rejection (example)	Rejection	Acceptance	0
				Acceptance (Example)	Acceptance (example)	1 (example)
Remote controller off only accepted	Acceptance	Acceptance	Acceptance	Rejection	Acceptance	2
				Acceptance	Rejection	3
				Rejection	Acceptance	4
				Acceptance	Rejection	5
Central priority	Acceptance	Acceptance	Acceptance	Rejection	Acceptance	6
				Rejection	Rejection	16
				Acceptance	Acceptance	7
				Rejection	Rejection	17
Individual priority (Last command priority)	Acceptance (only when timer is ON.)	Rejection (only when timer is OFF.)	Acceptance	Rejection	Acceptance	8
				Rejection	Rejection	18
				Acceptance	Acceptance	9
				Rejection	Rejection	19

**Notes:**

- : Settings when shipped from factory.
- If not using remote controller, do not select the remote controller permission timer is not operable and should not be set.

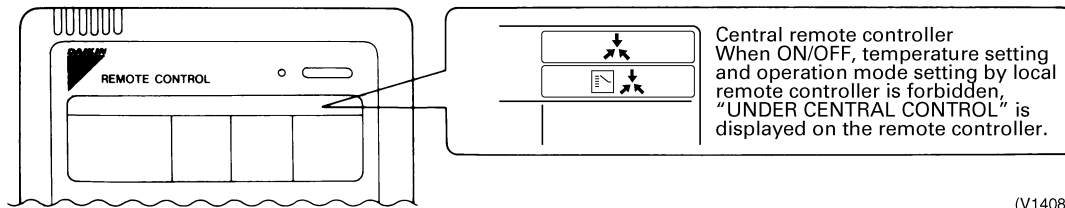

■ Timing Chart for Scheduled Operation and each Control Mode No. (VRV system) are as follows:

1. Remote controller rejection: Code No. 0, 1, 10, 11

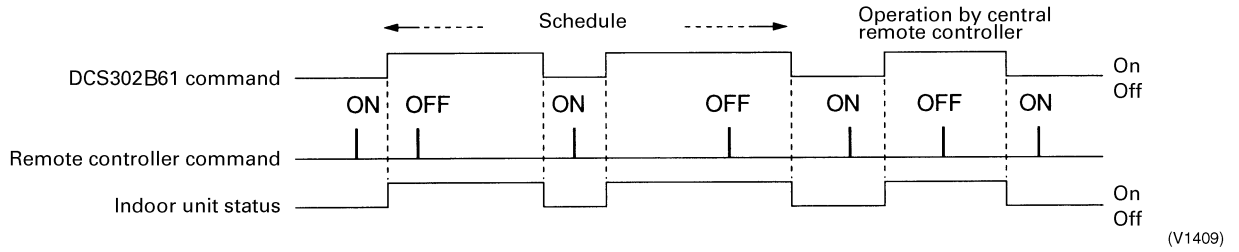

2. Remote controller off only accepted: Code No. 2, 3, 12, 13

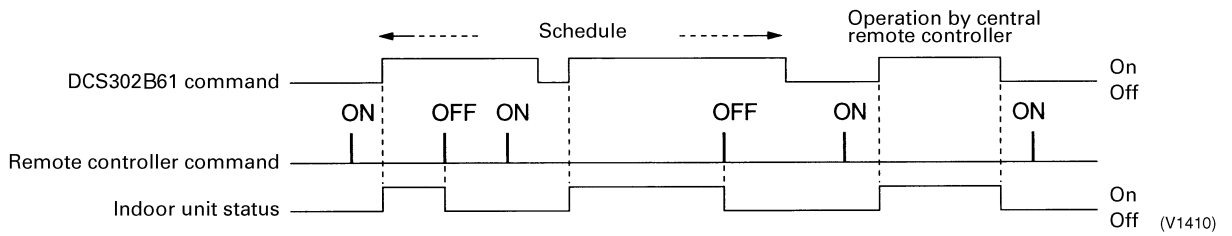

3. Central priority: Code No. 4, 5, 14, 15

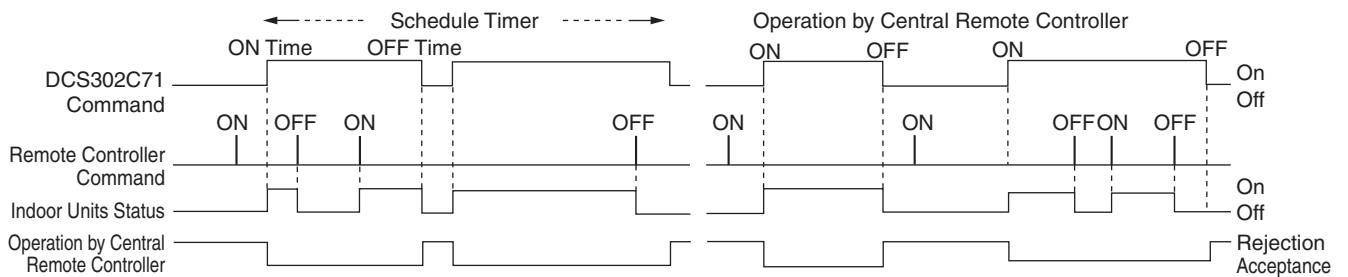

4. Individual priority - Last command priority: Code No. 6, 7, 16, 17

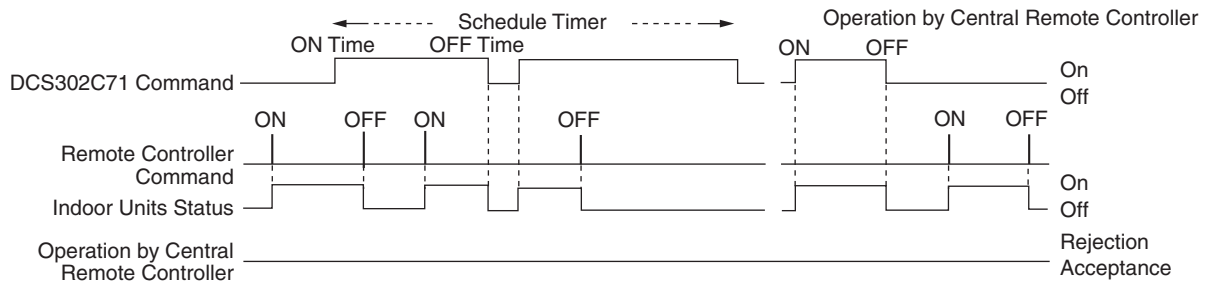

**5. Remote controller permission timer: Code No. 8, 9, 18, 19**

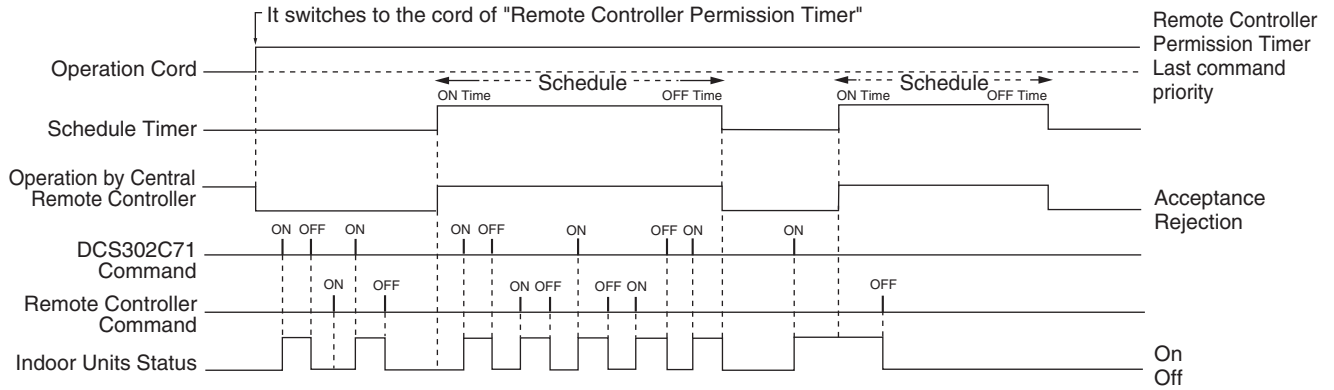

Note: Operation by remote controller is the same as central priority.

### 2.4.8 Setting of Central Remote Controller: Be sure to set 1 ~ 3 before electrical power is supplied.

**1. Connector for setting MAIN for control is provided when shipped from factory**

- When only one central remote controller is used, never remove the connector for setting MAIN for control.
- When plural central remote controllers are used or a central remote controller is used with other central controllers, the setting should be made according to the following table:

Pattern of central control equipment connection.			Connector for setting Main for control		
Central remote controller	Unified ON/OFF controller	Schedule timer	Central remote controller	Unified ON/OFF controller	Schedule timer
1~4 units	—	—	Use for 1 unit only. Not use for other units.	—	—
	1~16 units	—		Not used for all units	—
	—	1 unit			Not used.
—	—	1 unit	—	Not used.	

Note: Be sure to remove the connector when the Parallel interface or Data station is used.

**2. Control range setting switch (SS3)**

- This setting is required when up to 128 groups of indoor units are controlled by two central remote controllers.

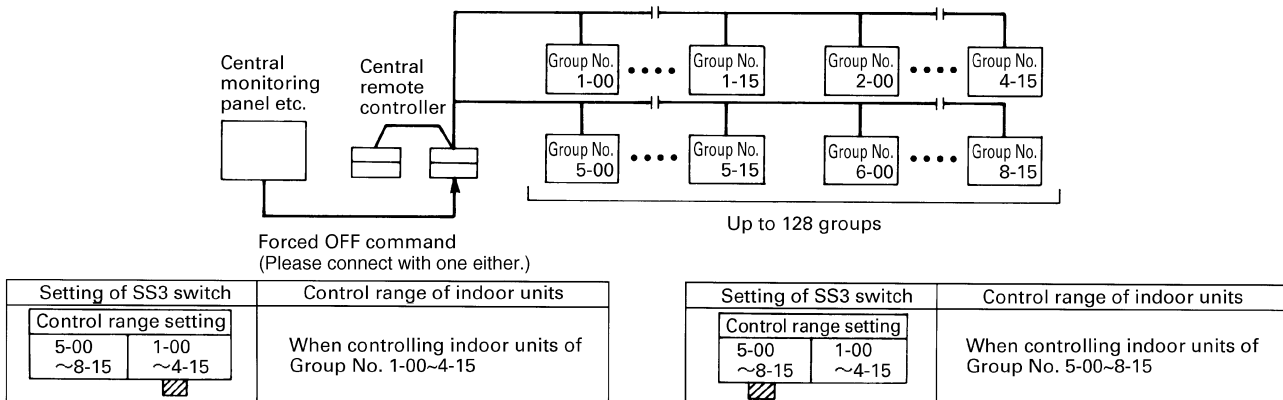

(V1414)

**3. Main/Sub changeover switch: Setting is required for central control from 2 locations**

- This is required when you have central control of the same indoor unit(s) from different places by using 2~4 central remote controllers.

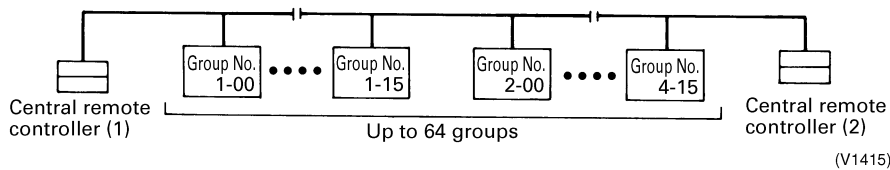

(V1415)

Either Group 1 or 2 of the central control equipment should be set for Main, and the other one for Sub.

**4. Forced reset switch**

When changing the setting of the connector for the main controller, you can reset simply by setting it to the reset side once and returning to the normal side, without turning the power OFF. For normal operation, set the switch to the normal OFF side.

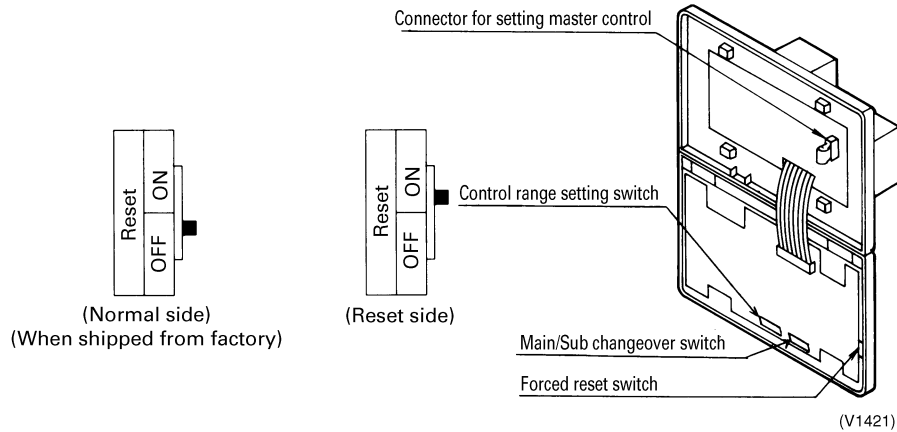

**5. Special Function Settings**

Special functions on the central control system can be changed while in FIELD SETTING mode.

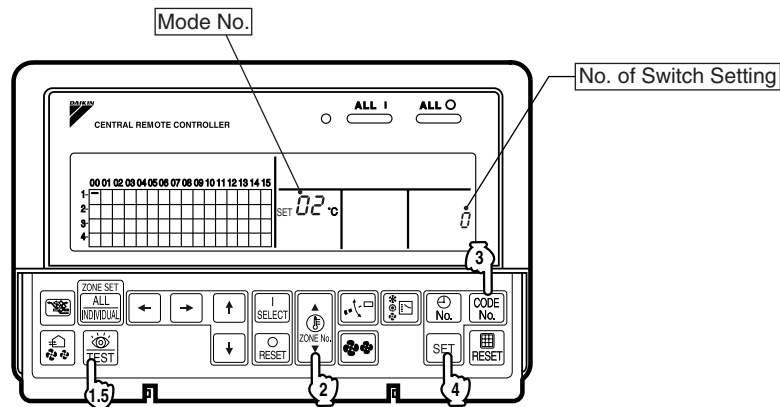

**Setting Procedure**

1. Press and hold the **TEST** button for four seconds or more to set the system to FIELD SETTING mode.
2. Use the **ZONE No.** button to select a desired temperature. Press ▲ to increase the Mode No. Press ▼ to decrease the Mode No.
3. Press the **CODE No.** button for control mode to select a **Switch Setting No.**
4. Press the **SET** button to determine the content of the changed setting. The blinking display then reads **Switch Setting No.**
5. Press the **TEST** button to return the system to NORMAL mode. In this case, you do not need to turn cycle the power again.

Example: If no restricted items from the sub-central remote controller while in double-central control, set Mode No. to [02] and the Switch Setting No. to [0].

**6. Refreshed operation**

Refreshed operation is the default setting from the factory and enables setting of TEMPERATURE CONTROL and TEMPERATURE SETTING automatically when turning on the unit from DCS302C71.

**7. Factory default setting**

OUTDOOR SYSTEMS	INDOOR UNITS
Cooling Mode	Cooling 82°F

Heating Mode	Heating 72°F
Fan Mode	Fan Operation

Examples of functionality with Refreshed Operation:

If the setting is changed by DCS302C71, the unit operates by this setting from the next operation. If originally set to 79°F cooling by DCS302C71, the next operation also operates at 79°F for cooling mode. Even if it has changed into heating operation, or fan-only operation with wired or wireless remote control, it operates at 79°F in cooling mode. When zone registration is entered into the Central Remote Controller, the next operation uses the value originally set up in the zone.

If Zone 1 is set to 68°F of heating ( see following figure) and controlled by Central Remote Controller, 3 indoor units registered into Zone 1 are operated by 68°F for heating. Because priority is given to zone setting, even if an individual mode for unit 2-02 from the Central Remote Controller is set to 77°F, 2-02 is operated at 68°F zone setting. If there are two or more indoor units in a zone, the operating mode depends on the outdoor unit, and the operating mode of each indoor unit does not become the same setting.

When the outdoor unit system 1 is cooling, outdoor unit system 2 is heating, as shown in the following figure. Setting of a zone 2 is operated in heating mode, because 2-03, 2-04, and 2-05 do not have a cooling/heating selection, and temperature reaches 79°F. When you unify the operating mode of an indoor unit in the same zone, you must set up a zone in the indoor unit to correspond with its outdoor unit system.

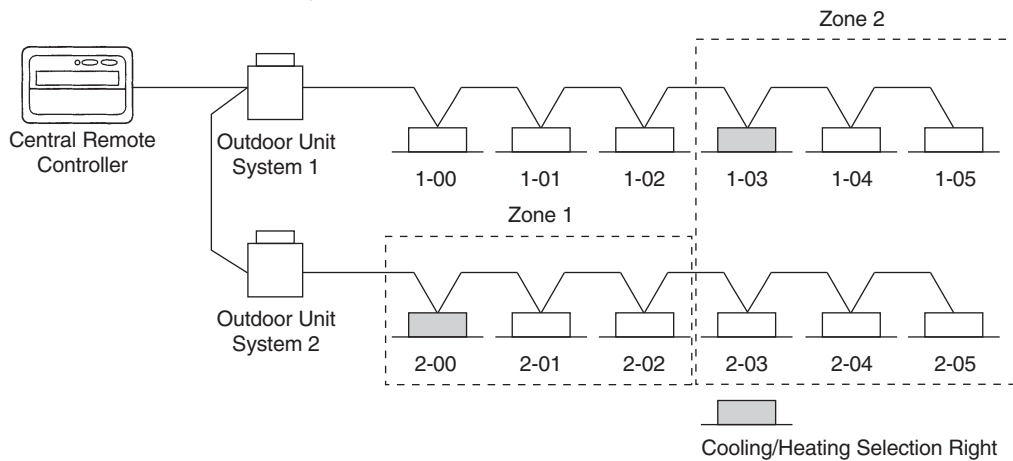

### Setting Contents and Setting No.

Mode No.	Setting contents	No. of setting switch		
		0	1	2
00	Setting of sequential operation function	NO	<b>YES</b>	–
01	Setting of refresh function	NO	<b>YES</b>	–
02	Setting of restriction items from sub-central remote controller while in double central control function	Disabled	<b>Enabled</b>	–
03	Setting of area designation for forced OFF (Operation with T1 and T2 entered)	Forced OFF all within the scope of control	Forced OFF only within the scope of control	Forced thermostat OFF with the scope of control

Items in bold represent the factory set for the No. of Switch Setting.

Do not make setting of any items not listed in the table above.

#### ■ Setting for Sequential start function

The central remote controller is equipped with the sequential start function, which starts the indoor units in about 2~3 seconds interval during the unified operation. (The switch is set to **ON** when shipped from factory.)

You can change the sequential start setting from **ON** to **OFF** as follows.

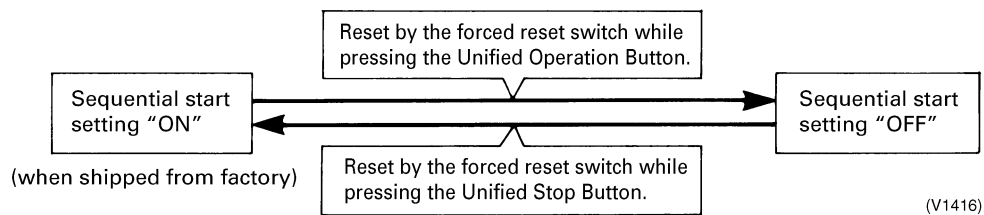

#### Note:

The sequential start function is for reducing the load of the electrical facility, but not for reducing the load of the large rush current when the compressors are started at the same time. This is also the same for Unified ON/OFF controller and Schedule timer.

#### ■ Refresh function

This function is used to automatically send OPERATION MODE and TEMPERATURE SETTING from the central control system while in operation. In order to disable the refresh function, set the **No. of Switch Setting** to [0].

#### ■ Restriction items from sub central remote controller while in double central control function

While in double central control function, no settings of zone interlock and operation code can be made from the sub central remote controller. In order to disable the refresh function from the sub central remote controller, set the **No. of Switch Setting** to [0].

#### ■ Setting of area designation for forced OFF

- In order to stop all indoor units within the scope of control as a single unit using the entry of T1 and T2, set the **No. of Switch Setting** to [1].
- In order to stop all indoor units within the scope of control with forced thermostat OFF using the entry of T1 and T2, set the **No. of Switch Setting** to [2]. With this parameter set to [2], no forced stop can be made on any indoor unit.

## Installation

- (1) Open the upper part of remote controller.  
Insert a ⊖ screwdriver (2 locations) into the recess between the upper part and the lower part of remote controller and twist the screwdriver lightly.

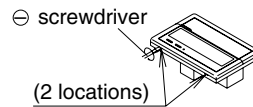

PC board is attached with both the upper and lower part of remote controller. Do not damage the board with the screwdriver.

- (2) Open the upper part of remote controller and install the Electric parts box with the attached installation screws (M4 × 16).

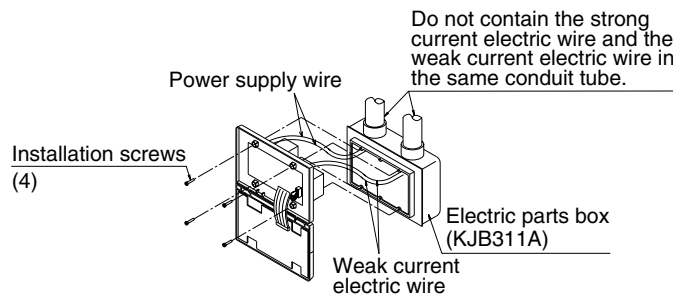

NOTE) Suitable length of the electric wire is about 6 1/4" from electric parts box. If it is difficult to contain a long wiring, strip the jacketed part of the wiring.

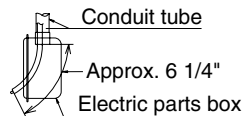



## 2.5 DCS301C71 Unified ON/OFF Controller

Turns up to 16 groups of indoor units (max. 128 units) on/off (operation/stop) by individual group or simultaneously and enables view of operation/malfunction at the same time.



- For a maximum of 16 groups of indoor units (max. 128 units), unified operation/stop or individual operation/stop can be performed with this optional accessory. Also allows you check operation/error display at a glance.
- By combining with a central remote controller and schedule timer, you can construct a system that matches the size and use of the building.
- Up to 8 units connectable within 1 system.  
Up to 16 units in the double central control mode.
- Applicable wiring methods include bus and star in addition to crossover type.
- Can be used in combination with other D-BACS equipment.

### 2.5.1 System Configuration

This unified ON/OFF controller enables individual and unified operation/stop for a maximum of 16 groups of indoor units. With 2 to 8 unified ON/OFF controllers, individual and unified control is possible with up to a maximum 128 groups of indoor units.

- When using 1 unified ON/OFF controller

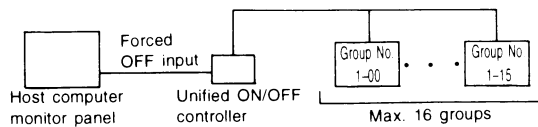

- When using 2 to 8 unified ON/OFF controllers

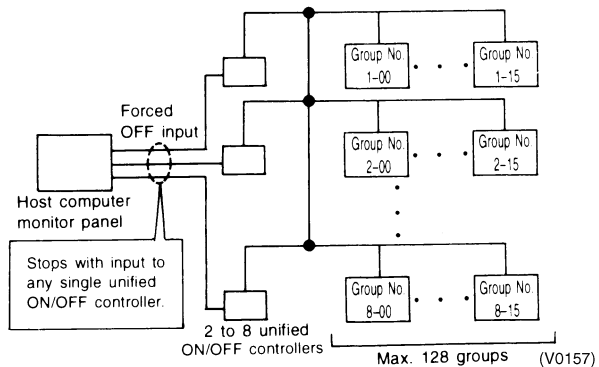

This optional accessory can not be used in conjunction with wiring adaptor, which is also an optional accessory, for electrical appendices.

**The groups of indoor units are as follows:**

1. One indoor unit without remote controller

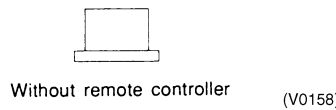

2. One indoor unit controlled by one or two remote controllers

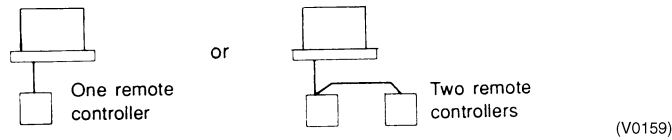

3. A maximum of 16 indoor units controlled in groups by one or two remote controllers

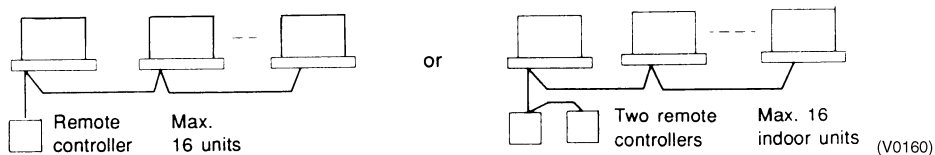

**2.5.2 Electric Wiring  
General Instructions**

- All wiring, components, and materials procured on the site must comply with the applicable local and national codes.
- Use copper conductors only.
- All field wiring and components must be provided by a licensed electrician.
- Unit shall be grounded in compliance with the applicable local and national codes.
- Fit the power supply wiring with a fuse and a switch.
- After wiring work, check power to ensure that the equipment shuts OFF when the switch is turned OFF.

**Wiring Outline**

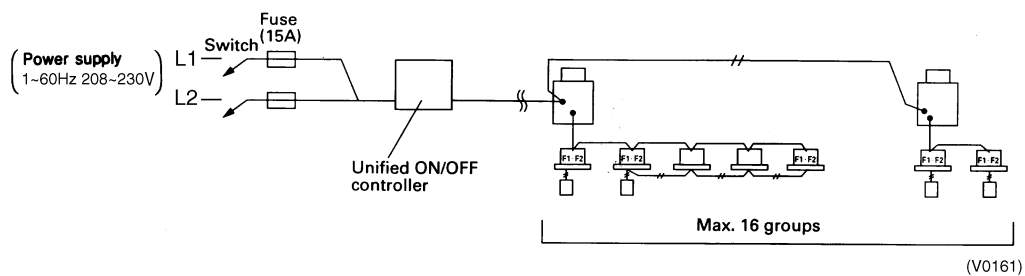

**Wiring Specification**

	Type	Size
Power Supply Wiring	H05VV-U3G	(Note 1)
Transmission Wiring	2-conductor, stranded, non-shielded copper cable / PVC or vinyl jacket	18-AWG

**Notes:**

1. The size of power supply wiring must comply with the applicable national and local codes.
2. Allowable length of transmission wiring is as follows.  
Max. 3280 ft; Total wiring length for all groups combined: 6560 ft

Connect the wiring between indoor and outdoor units, indoor/outdoor units and power supply, and indoor units and remote controllers. For details, refer to the installation manuals of indoor and outdoor units.

## Examples of Wiring for Transmission

### 1. Series Wiring

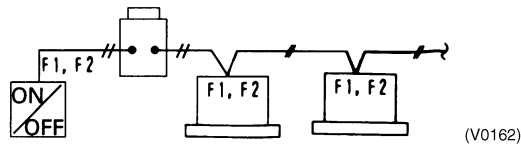

### 2. Bus Type Wiring: Can be branched up to 16 branches

Example of 3 branches

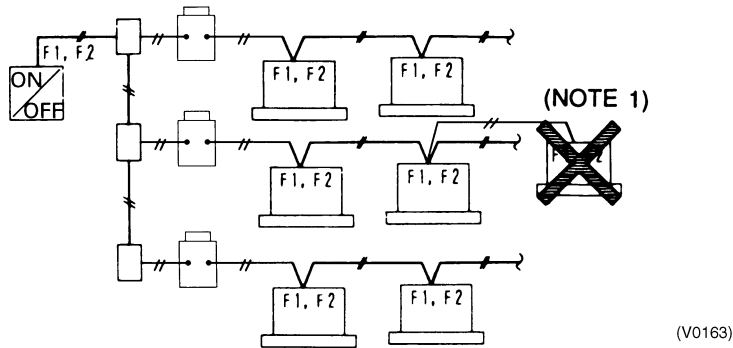

### 3. Star Type Wiring: Can be branched up to 16 branches

Example of 3 branches

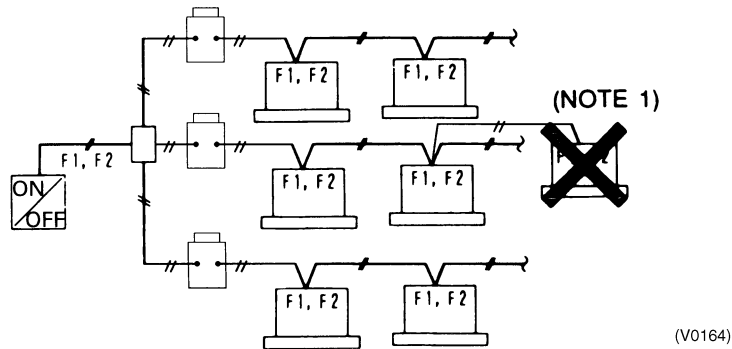

(V0165)

**Note:**

1. No branching is permitted from the daisy chain.
2. Use a relay terminal board (field supplied) to branch more than 3 control wires from the same terminal board.

Wiring to the Indoor Unit and Outdoor Unit

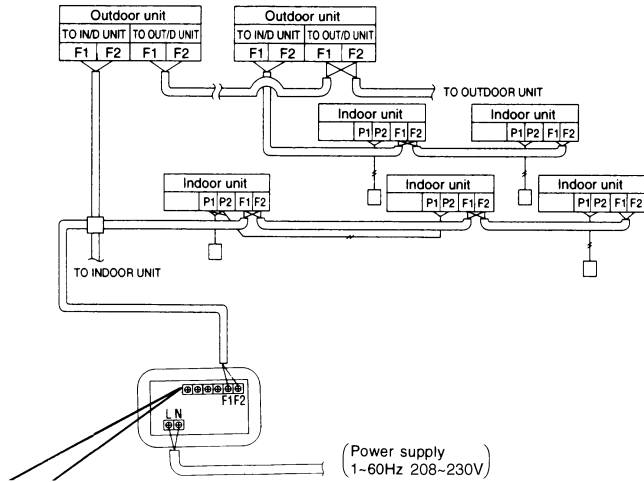

**CONTROL TERMINAL STRIP**

- \* 1 For connecting indoor unit (F1, F2)
- \* 2 Forced OFF input (T1, T2)  
While the forced OFF input (no voltage contactor, for micro current) is ON (energized), all the connected indoor units are stopped and can not be operated.  
Use only contactors which guarantee the minimum applicable load ∴ 16V, 10mA.  

T 1	—	⊖		
T 2	—	⊖	∴ 16V	

 NOTE) Use instantaneous contactor of over 200msec. energizing time, when necessary.
- \* 3 For schedule timer (D1, D2)  
Power can be supplied to the schedule timer (DST301B61/optional accessory). For details, refer to the installation manual of the schedule timer.  
Wire \* 2 and \* 3 only when necessary.

(V0166)



**WARNING:**

Do not connect the power supply wiring to the control terminal strip. If connected by mistake, it may damage or burn electrical parts of optional controllers for centralized control and indoor unit and can be dangerous. Be sure to check wirings before turning the power ON.

2.5.3 Dimensions

Unified ON/OFF Controller DCS301C71

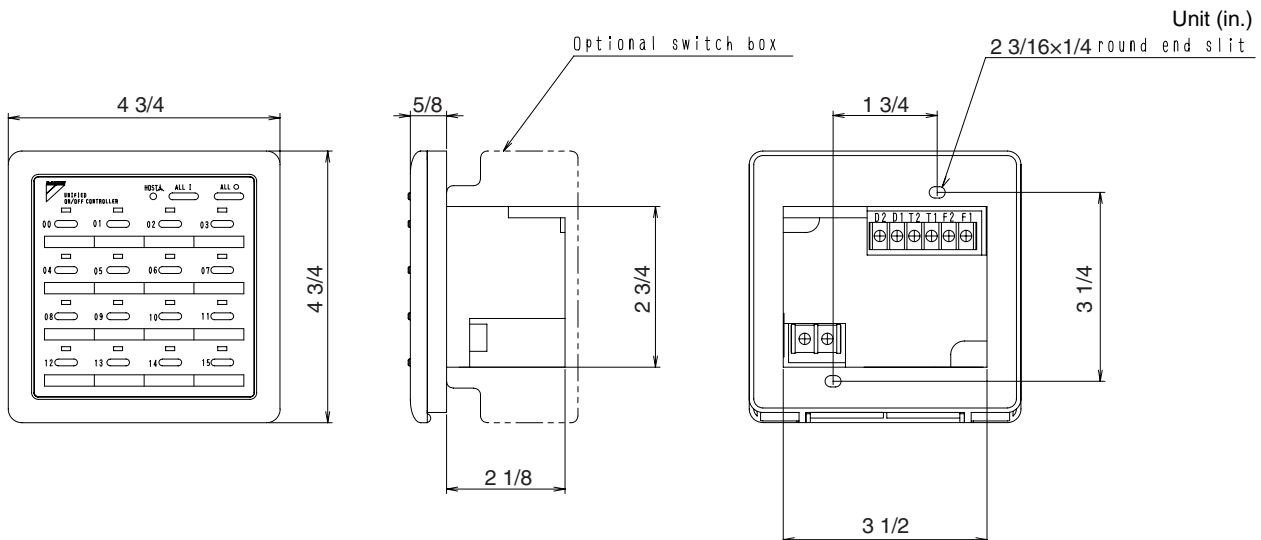

### 2.5.4 Installation

1. Open the upper part of remote controller.  
Insert a minus screwdriver (2 locations) into the recess between the upper part and the lower part of remote controller and twist the screwdriver lightly.

**PC board is attached with both the upper and lower part of remote controller. Do not damage the board with the screwdriver.**

2. Open the upper part of remote controller and install the electrical box, procured in the field, with the attached installation screws (M4×16).

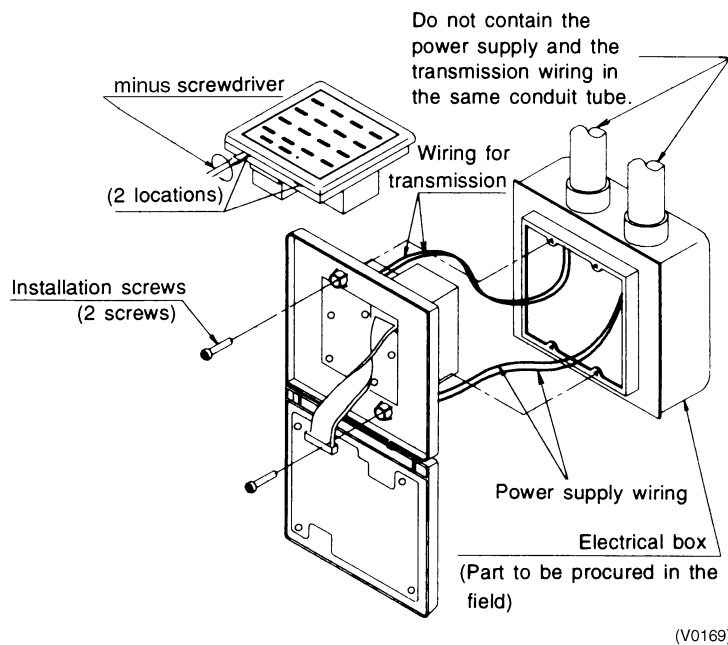
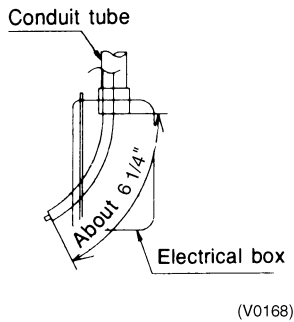

**Note:** Suitable length of the electric wire is about 6-1/4" (160 mm) from the inlet of the electrical box. If it is difficult to contain a long wiring, strip the jacketed part of the wiring.

### 2.5.5 Initial Setting

1. **Connector for setting master controller (X1A) is provided with connector at factory set.**
  - When using 1 unified ON/OFF controller, do not disconnect the connector for setting master controller. Use the unit with the connector in the state in which it was delivered.
  - When using multiple unified ON/OFF controllers, or using the unified ON/OFF controller in conjunction with other optional controllers for centralized control, makes settings as indicated in the right table.

Pattern of connection of optional controllers for centralized control			Connector for setting master controller (X1A) Settings		
Unified ON/OFF Controller	Central Remote Controller	Schedule Timer	Unified ON/OFF Controller	Central Remote Controller	Schedule Timer
1 to 16	—	—	Set one to <b>USED</b> and all the rest to <b>NOT USED.</b>	—	—
	1 to 4	—	Set all to <b>NOT USED.</b>	(Note)	—
	—	1	Set one to <b>USED</b> and all the rest to <b>NOT USED.</b>	—	<b>NOT USED.</b>
	1 to 4	1	Set all to <b>NOT USED.</b>	(Note)	<b>NOT USED.</b>

**Note:**

For instructions on how to set the master controller on the central remote controller, see the installation manual provided with the central remote controller.

**2. Switch for Setting Each Address (DS1)**

The following switches are used to set group control address:

Group Numbers 1-00 through 1-15 are in the same control group when the unit is shipped from the factory.

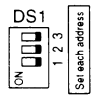
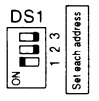
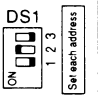
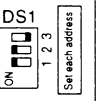
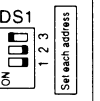
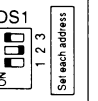
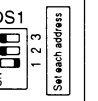
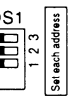
Each Address	1-00~1-15	2-00~2-15	3-00~3-15	4-00~4-15	5-00~5-15	6-00~6-15	7-00~7-15	8-00~8-15
DS1 setting	 (Factory setting)							

(V0170)

After setting, attach the number seal applicable to respective control range of the attached switch display sticker, as shown in the diagram below.

Example:

In The Case of 1-00 to 1-15, Attach 1.

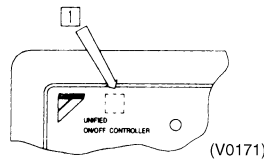

(V0171)

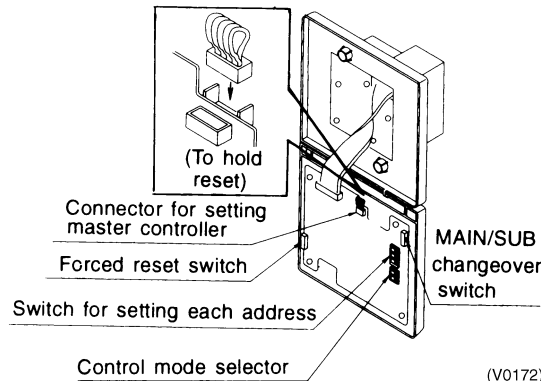

(V0172)

**3. MAIN/SUB Changeover Switch Setting**

With two unified ON/OFF controllers, centralized control for indoor units is possible from different locations. In this kind of setup, it is necessary to set the MAIN/SUB changeover switch.

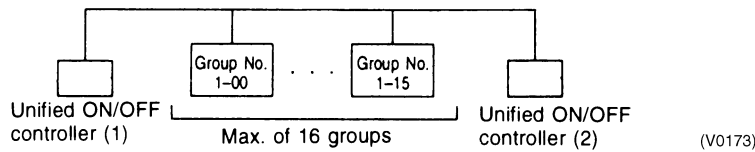

(V0173)

One of the two unified ON/OFF controllers (1) is set to MAIN while the other (2) is set to SUB.

**4. Setting of the Sequential Operation Function**

The unified ON/OFF controller is equipped with a sequential operation function that sequentially turns indoor units on in 2-second intervals during unified operation. Sequential operation is factory set to ON. To switch sequential operation ON or OFF, set as shown in the following diagram:

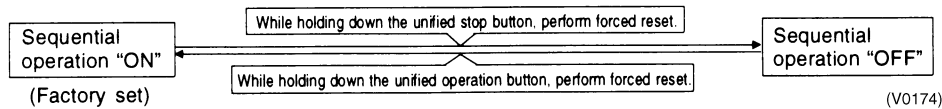

(V0174)

**Note:**

The sequential operation function is designed to reduce the load on the power supply equipment, but does not guarantee that compressors will not be started simultaneously. You cannot count on a capacity reduction when selecting equipment breakers.

**5. Control Mode Selector (DS2)**

The following four patterns of control mode can be set:

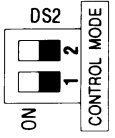
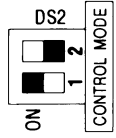
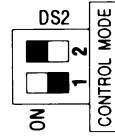
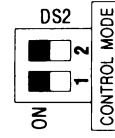
Control Mode	Individual	Centralized	Timer Operation Possible by Remote Controller	ON/OFF Control Impossible by Remote Controller
Content	Operation/stop is controlled by both unified ON/OFF controller and remote controller.	After operation by unified ON/OFF controller, operation/stop is freely controlled by remote controller until stopped by unified ON/OFF controller.	When used in conjunction with the schedule timer, operation/stop is controlled freely by remote controller during the set time but operation is not available when the schedule timer is ON.	Operation/stop is controlled by unified ON/OFF controller only. This unit can not be operated/stopped by remote controller.
DS2 Setting	 <p>(V0175)</p> <p>(Factory set)</p>	 <p>(V0176)</p>	 <p>(V0177)</p>	 <p>(V0178)</p>

**Note:**

- ■ Indicates the position of switches.
- Set control mode before turning power supply ON.
- When used in conjunction with central remote controller, the control modes of the central remote controller takes priority.

**6. Forced Reset Switch (SS1)**





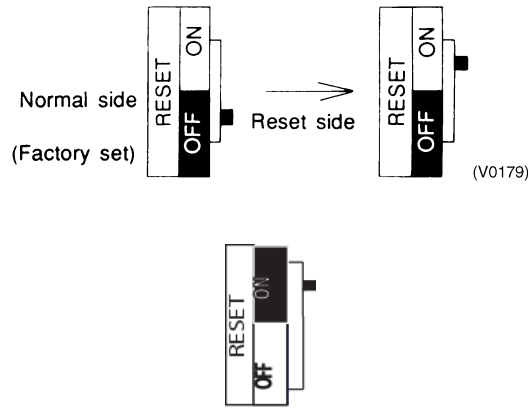

When changing the setting of the connector when setting the master controller, you can reset simply by switching it to the reset side and back again without turning the power OFF.

For normal operation, set the switch to the normal, or off position, side.



## 2.5.6 Setting Group No. for Centralized Control

Set the group number of each group of the indoor unit from the remote controller. In no remote controller, also connect the remote controller and set the group number and remove the remote controller.

1. Turn ON the power of the indoor unit and unified ON/OFF controller. The power must be ON to apply settings. Check that the installation and electrical wiring are correct before turning the power supply ON. When the power supply is turned ON, all LCD appear once and the unit may not accept the operation for about one minute with the display of  flashing in an interval of ON-ON-OFF.
2. While in the normal mode, hold down the  button for a minimum of 4 seconds. The remote controller will enter the FIELD SET MODE.
3. Select the MODE No. [00] with the  button.
4. Use the  button to select the group No. for each group. (Group numbers increase in the order of 1-00, 1-01, ...1-15, 2-00, ... 8-15.)
5. Press  to set the selected group No.
6. Press  to return to the NORMAL MODE.

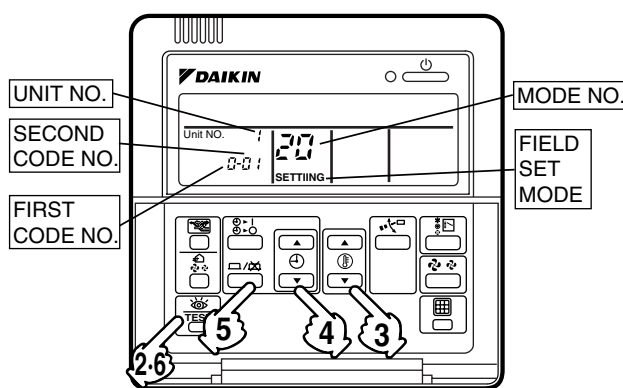

(V1910)

### Note:

- For simplified remote controller, see the installation table.
- For setting group numbers for wiring adaptors on other air conditioners, refer to its accompanying instruction manual

### NOTICE

Enter the group number and installation location of the indoor unit into the attached installation table. Be sure to keep the installation table with the operation manual to enable proper maintenance.

## 2.5.7 Confirming Operation

Before starting test operation, supply power to the indoor units, outdoor units, and unified ON/OFF controller, and press the ON/OFF BUTTON.

If the operation lamp flashes, it indicates a malfunction in the indoor unit of the applicable group.

If the display of  flashes, it indicates a malfunction in the optional centralized controllers and should be checked.

### Note:

- For test operation of indoor and outdoor units, refer to the outdoor unit's accompanying installation manual.
- After turning the power supply ON, if the unit does not accept operation for two minutes or more with the display of  flashing, check the following points:
  - Check that the connector is set correctly for setting master controller.
  - Check that the group number for centralized control has been set.



## 2.6 DST301BA61 Schedule Timer

Enables you to connect and control weekly schedules for up to 128 indoor units.



- Simultaneous control of up to 128 indoor units is managed by a week schedule.
- The start and stop time for twice a day can be set for the week in increments of 1 minute.
- By combining with a central remote controller and schedule timer, you can construct a system that matches the size and use of the building.
- If used together with a central remote controller, you can set up to 8 schedule patterns that can be distributed among zones using the central remote controller.
- Is equipped with a compensation function for power failure up to 48 hours.
- Features thin design of a mere 5/8" in thickness using JIS recessed box for 2.
- Applicable wiring methods include bus and star in addition to crossover type.
- Can be used in combination with other D-BACS equipment.

### 2.6.1 System Configuration and Electric Wiring

With a schedule timer, you can set on/off time twice a day in time increments of 1 week for up to 128 indoor units.

- System Configuration

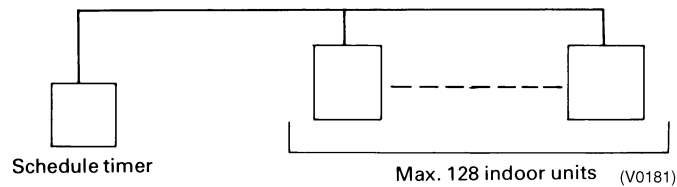

If using the schedule timer alone, you don't have to set the centralized control group number.

- Transmission Wiring

#### Indoor Unit Wiring:

1. If using the schedule timer alone:

- For the schedule timer's power supply, connect the schedule timer (D1, D2) with the connector (X18A) on the indoor unit PC board by crimped style terminal with the attached electrical wire.

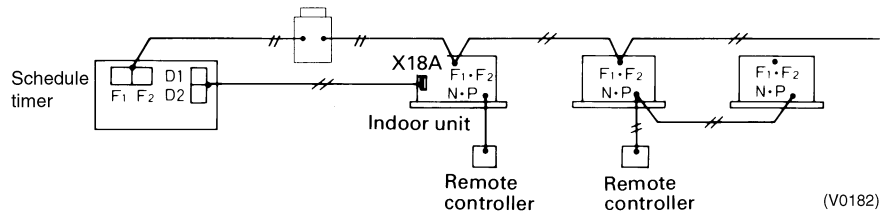

2. If using in combination with other optional controllers for centralized control:

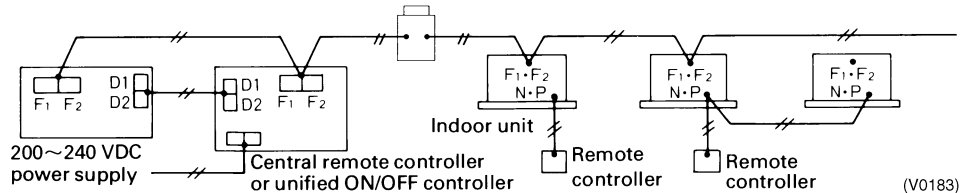

Transmission wiring for control: AWG 18 , 2-conductor, stranded, non-shielded copper cable / PVC or vinyl jacket, Max. 3280 ft (Total Max. 6560 ft)

**Transmission Wiring Connection Example: 1 series wiring, 2 bus wiring, and 3 star wiring are the same style as the central remote controller.**

2.6.2 Names and Functions DST301BA61

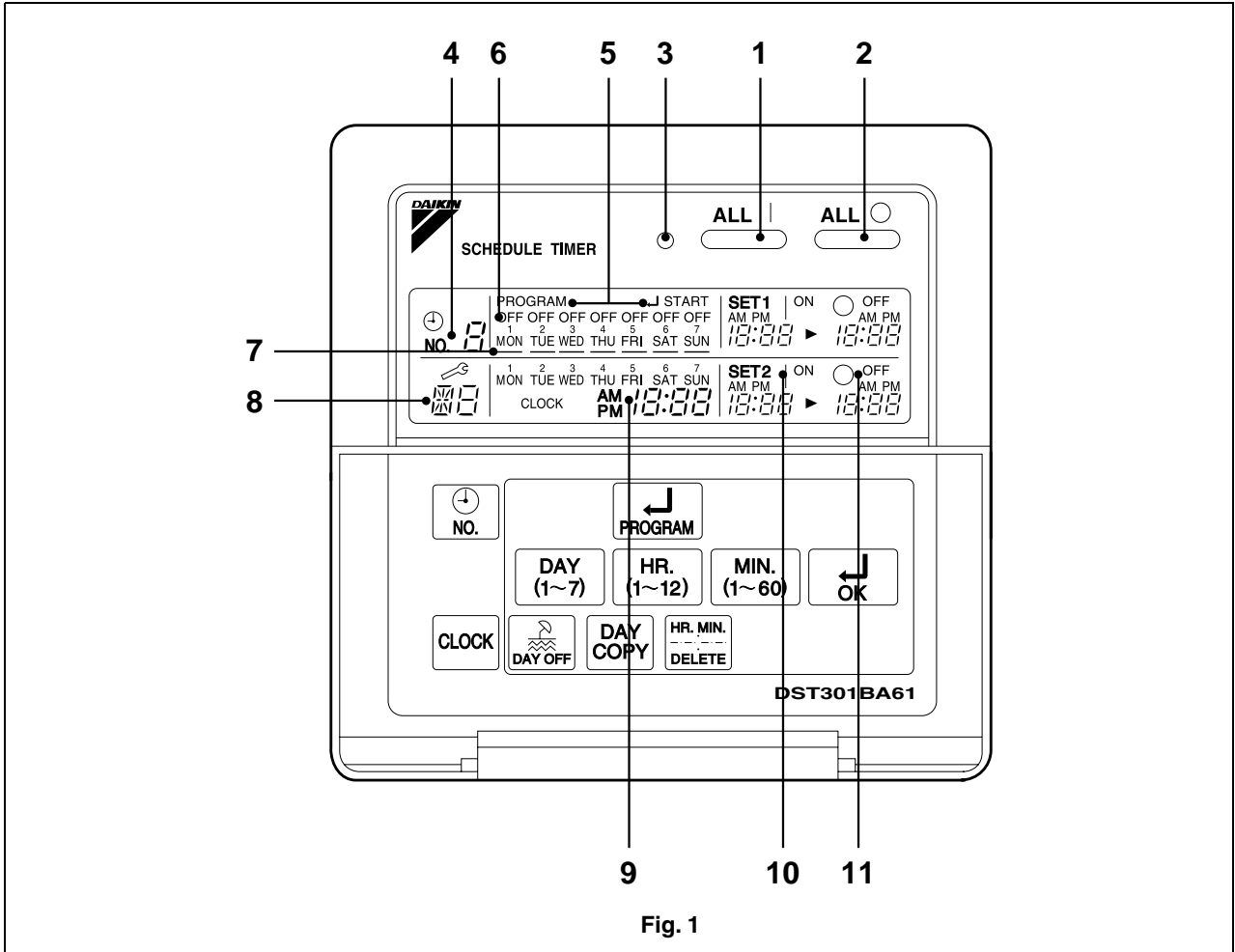

Fig. 1

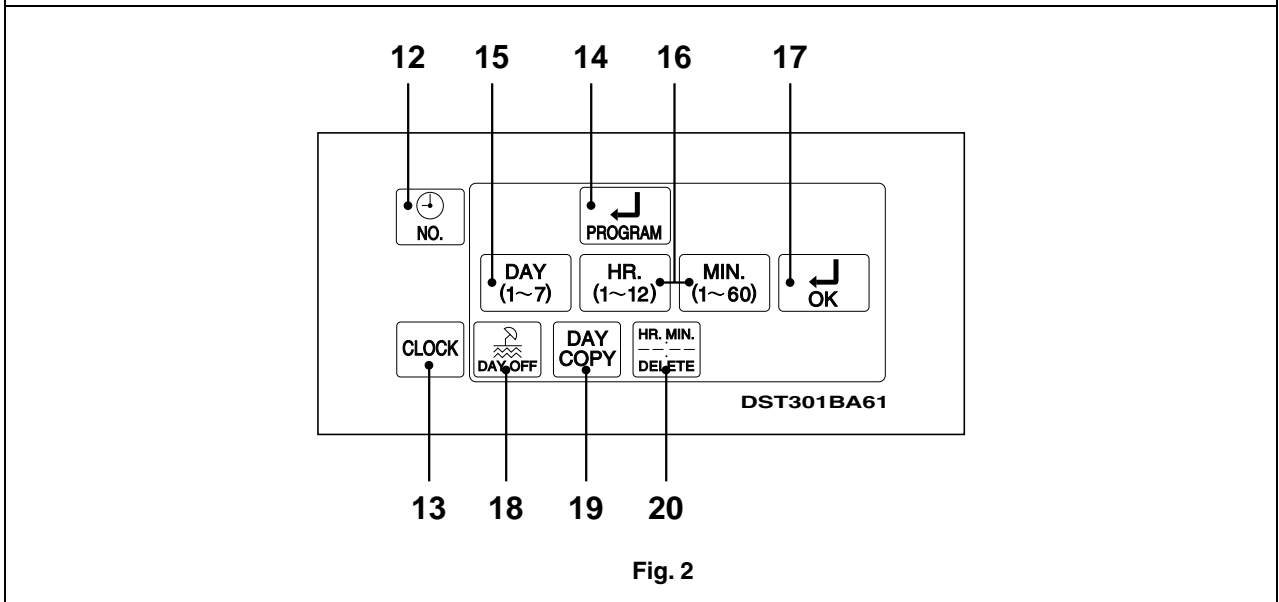





















Fig. 2

3P124623-5C

1	<b>UNIFIED OPERATION BUTTON</b> 
	Press to perform the unified operation regardless of the programmed time.
2	<b>UNIFIED STOP BUTTON</b> 
	Press to perform the unified stop regardless of the programmed time.
3	<b>OPERATION LAMP (RED)</b>
	The light turns on during the operation of the indoor unit.
4	<b>DISPLAY</b>  <b>TIME No.</b>
	Displays the time number only when used in conjunction with the central remote controller.
5	<b>DISPLAY PROGRAM</b>  <b>START.(PROGRAMMING START)</b>
	The light turns on when the timer is programmed.
6	<b>DISPLAY OFF</b> For <b>HOLIDAY SETTING</b>
	Lights above the day of the week set as holiday. The operation controlled by timer is not available on that day.
7	<b>DISPLAY</b> [—] ( <b>SETTING OF DAYS OF A WEEK</b> )
	Flashes below the day of the week programmed.
8	<b>DISPLAY</b>  ( <b>MALFUNCTION CODE</b> )
	Displays the contents of malfunction during the stop due to malfunction.
9	<b>DISPLAY</b>  <b>(PRESENT TIME)</b>
	Displays the present day of the week and time.
10	<b>DISPLAY</b>  <b>PROGRAMMED TIME OF SYSTEM START</b>
	Displays the time programmed to start.
11	<b>DISPLAY</b>  <b>PROGRAMMED TIME OF SYSTEM OFF</b>
	Displays the time programmed to stop.
12	<b>TIME NO. BUTTON</b> 
	Press to select time schedules.
13	<b>CLOCK ADJUSTING BUTTON</b> 
	Press this button to set the present time.
14	<b>PROGRAMMING START BUTTON</b> 
	Press to set or check the programmed time. Press it again after you are through with the program.

15	<b>BUTTON FOR SELECTING DAYS OF A WEEK</b> 
	Press to select the day of the week.
16	<b>HOUR/MINUTE BUTTON</b>  
	Press to adjust the present time and the programmed time.
17	<b>TIMER ON BUTTON</b> 
	Press to set the present time and the programmed time.
18	<b>HOLIDAY SETTING BUTTON</b> 
	Press to set holidays.
19	<b>BUTTON FOR COPYING PROGRAM OF PREVIOUS DAY</b> 
	Use this button to set the No. of programmed time same as that of the previous day.
20	<b>PROGRAM CANCELING BUTTON</b>  
	Use this button to set the programmed time to cancel. The display shows [ -- ; -- ]
<p>Note:</p> <p>Please note that all displays are simultaneously shown in the figure to illustrate available options.</p>	

### 2.6.3 Dimension

#### Schedule Timer

■ DST301BA61

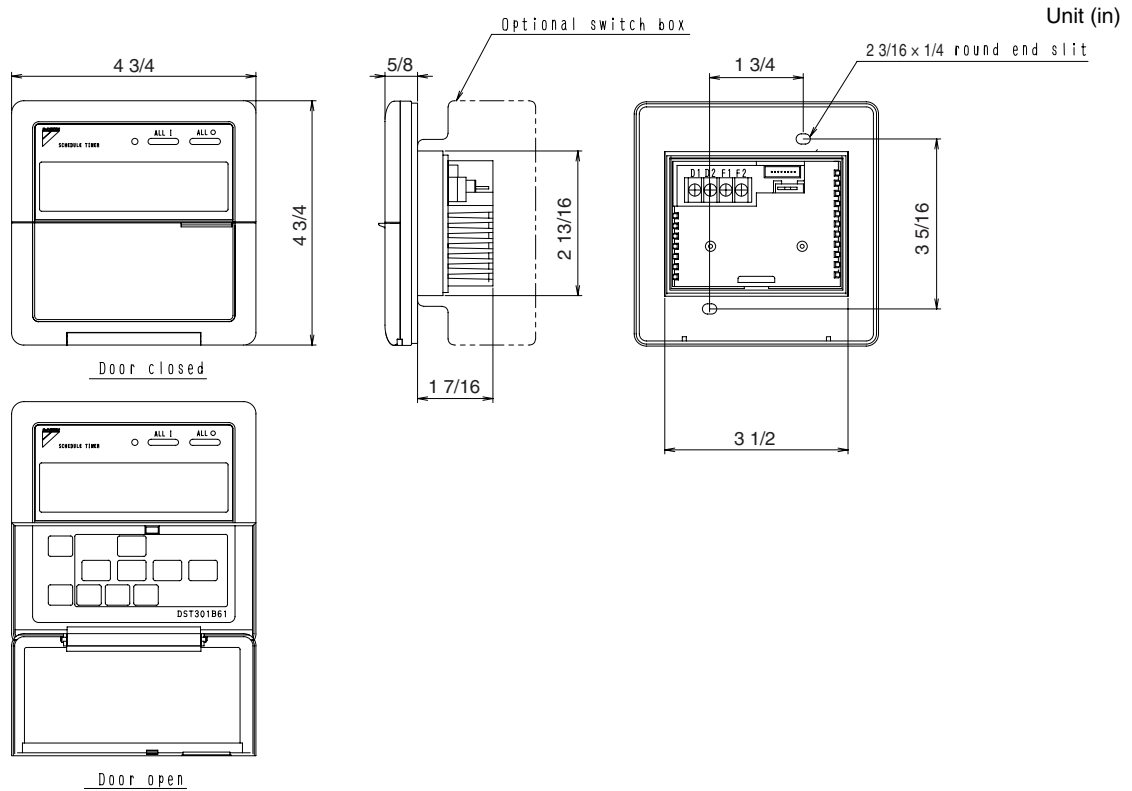

C:3D049544

### 2.6.4 Installation and Initial Setting

#### 1. Remove the upper part of the remote controller.

- Insert a screwdriver (2 locations) into the recess between the upper part and the lower part of the remote controller and turn the screwdriver lightly. The PC board is attached with the upper part of the remote controller. Do not damage electric parts with a screwdriver or other tools.

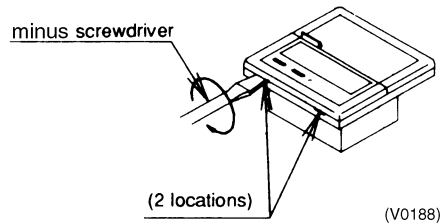

- Attach the lower part to the electrical box (part to be procured in the field) with the provided installation screws. Select a flat face as an installation place. Do not tighten the installation screws excessively or it might damage the lower part of the remote controller.

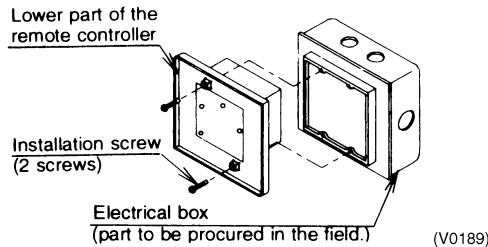

For electrical box, use part number KJB211A (optional accessory).

## 2. Initial Setting

### 1. Setting connector for individual use (X1A): Factory set : OFF -- Set for individual use only

- **For individual use of schedule timer**  
Insert the connector attached with the body case on the PC board.
- **For combined use with other optional controllers for centralized control**  
Do not change the factory setting.

### 2. Control mode selector (SS2): Set for individual use only

By changing the switch, setting mode of individual and centralized operation is available.

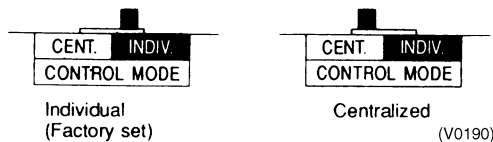

#### Note:

When used with other optional controllers, control mode of central remote controller and the unified ON/OFF controller take priority.

### 3. Setting of the sequential operation function

The schedule timer is equipped with a sequential operation function that sequentially turns indoor units on in 2-second intervals during unified operation.

Sequential operation is factory set to ON.

To switch sequential operation ON or OFF, set as follows.

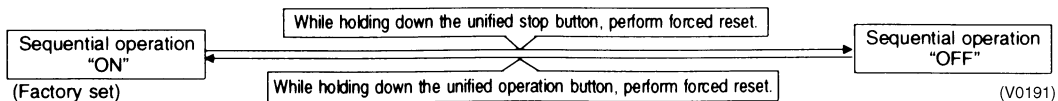

#### Note:

The sequential operation function is designed to reduce the load on the power supply equipment, but does not guarantee that compressors will not start simultaneously. You cannot count on a capacity reduction effect by power supply equipment breaker selection.

**4. Forced Reset Switch (SS1)**

When changing the setting of the connector for individual use, the switch can be reset simply by setting it to the reset side once and returning to the normal side. This procedure enables to reset without turning off the power. Set the normal side at normal operation.

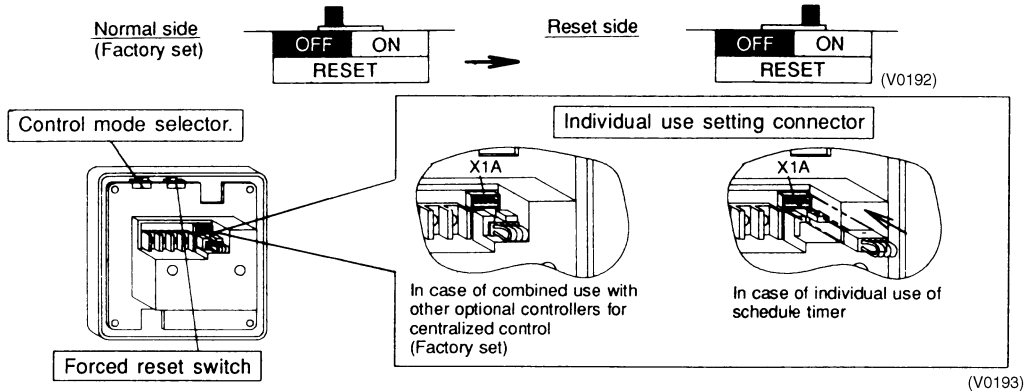

**5. Setting for special function**

When you want to have programmed operation for some functions of indoor units by using only the schedule timer, cut off J1 and supply the power again.

You can have a programmed operation of the indoor units. Set the address for central control by local remote controller.

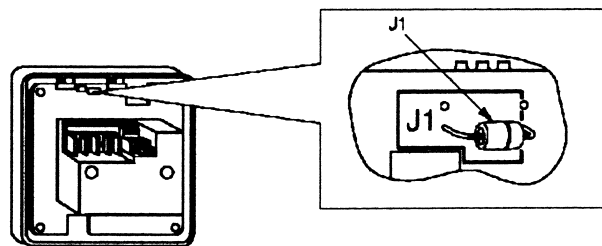

**3. Transmission Wiring**

- **In case of individual use of schedule timer, take the following action:**
- Connect terminals of the schedule timer (F1, F2) with terminals of the indoor unit (F1, F2). Connect terminals of the schedule timer (D1, D2) and the connector on the indoor unit PC board, using the attached electric wire and crimp style terminals. Prevent the connection part of crimp style terminal from hanging outside the electric parts box. **In case of combined use with other optional controllers for centralized control, take the following action:** Connect terminals of the schedule timer (F1, F2, D1, D2) and the terminals of the central remote controller or unified ON/OFF controller.

**Wiring Specifications**

	F1, F2	D1, D2
Wiring	2-conductor, stranded, non-shielded copper cable / PVC or vinyl jacket	2-conductor, stranded, non-shielded copper cable / PVC or vinyl jacket
Gauge	AWG18	AWG18
Length	Max. 3280 ft. (1000 m)	Max. 492 ft. (150 m)

**NOTES:**

1. Electrical box and transmission wiring are not attached.
2. Do not touch the PC board with your hand.
3. Keep transmission wiring at least 2 inches away from power supply wiring to prevent malfunctions.

#### 4. Install the Upper Part of the Remote Controller as before.

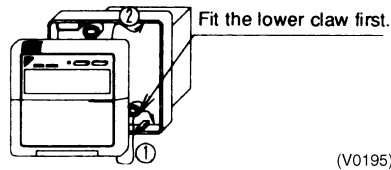

### 2.6.5 Error Diagnosing Function

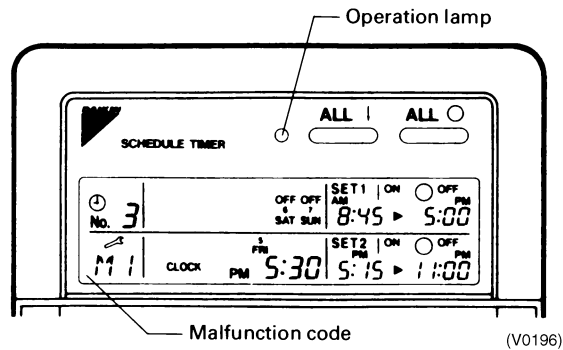

This schedule timer is provided with the malfunction-diagnosing function. The malfunction code flashes if there are any communication malfunctions between the optional controllers for centralized control. In addition, the operation lamp also flashes if there are any malfunctions with the indoor unit. Check the display and contact your DAIKIN dealer to report the trouble area indicated.

Operation Lamp	Malfunction Code	Malfunction
Turn Off	M1	Failure of PC board of schedule timer
Turn On or Off	M8	Malfunction of transmission between each optional controller
Turn On or Off	MA	Improper combination of optional controllers
Turn On or Off	MC	Address failure of schedule timer
Flash	UE	Malfunction of transmission between indoor unit and optional controllers
Flash	—	Malfunction in indoor unit: Refer to the malfunction codes of the indoor remote controller, and read the accompanying <b>CAUTION FOR SERVICING</b> manual.

## 2.7 BRC1D71 7-Day Programmable Controller

New, advanced functions are as follows:



- Includes ventilation mode and airflow rate switching, the main functions of HRV series.
- 24-hour clock function with 1-hour backup for power failures.
- Programming function for each day of week.
- Scheduling for start/stop and temperature limits with 5 settings/day
- Programming can be enabled or disabled.
- Copy function for programmed schedules.

### 2.7.1 Dimension

#### ■ BRC1D71

Unit (in.)

NOTE) 1. REMOTE CONTROLLER CORD AND STAPLE ARE NOT ATTACHED, THEY ARE FIELD SUPPLIED PARTS,

#### • REMOTE CONTROLLER DIMENSIONS

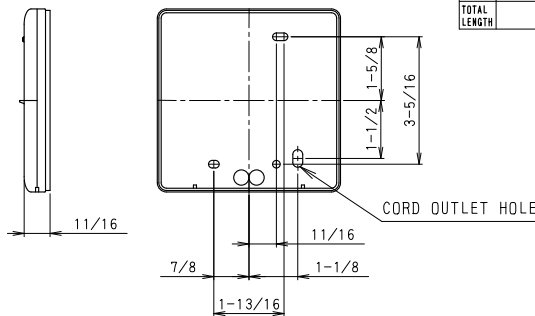
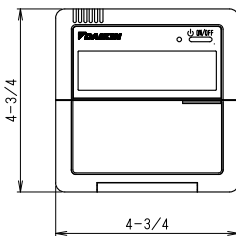

#### • SPECIFICATIONS OF CORD

TYPE	VINYL CORD WITH SHEATH OR CABLE (INSULATED THICKNESS: 1MM OR MORE)
SIZE	AWG16 OR AWG18
TOTAL LENGTH	16.40ft.

#### • INSTALLATION METHOD

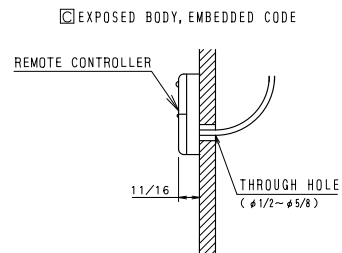
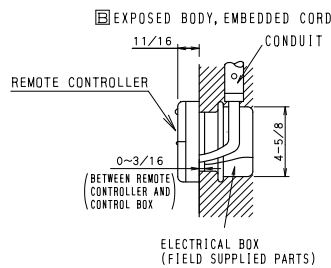
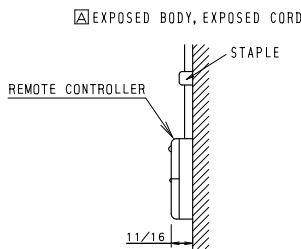

3D050574



### 2.7.2 Features and Functions

The BRC1D71 is a state-of-the-art remote controller that offers full control.

#### 1 **BASIC REMOTE CONTROLLER FUNCTIONS**

##### **ON/OFF**

- Operation mode change-over
- Temperature adjustment
- Air volume adjustment
- Air flow direction adjustment

#### 2 **CLOCK FUNCTIONS**

- 24 hours real time clock
- Day of the week indicator

#### 3 **SCHEDULE TIMER FUNCTIONS**

- Maximum of 5 actions can be programmed for each day of the week
- Schedule timer can be enabled/disabled at any time
- Linked to a set temperature or a LIMIT operation or an OFF operation
- The most recent command overrules previous command until next scheduled command

#### 4 **LIMIT OPERATION**

**Limit Operation** provides thermostat control within the range of the set minimum and maximum temperature. The minimum temperature setting will trigger heating, the maximum temperature setting will trigger cooling.

#### 5 **AWAY**

The **Away** function prevents the room temperature from dropping or rising when the occupants are out for a longer period. If the room temperature drops below 50°F, heating is started automatically. As soon as 59°F is reached, the controller returns to its original status. If the room temperature rises above 85°F, cooling is started automatically. As soon as 74°F is reached the controller returns to its original status.

#### 6 **BUTTON PERMISSION LEVEL**

Three hierarchical permission levels can be set to limit user action.

### 2.7.3 Function Labels Displayed

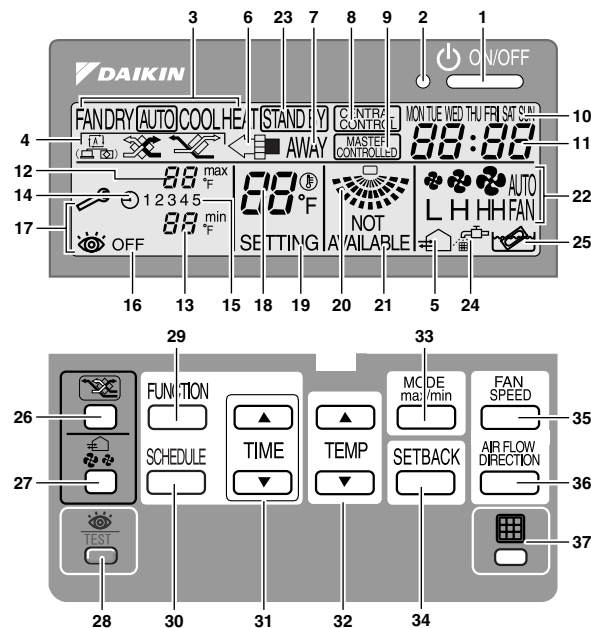



Figure 1

### 2.7.4 Name and Function of Switches and Icons (Refer to figure 1)

1 ON/OFF BUTTON  ON/OFF  
Press the ON/OFF button to start or stop the system.

2 OPERATION LAMP   
Lights during operation or blinks if a malfunction occurs.

3 OPERATION MODE ICON FAN DRY/AUTO/COOL/HEAT  
These icons indicate the current operation mode (FAN, DRY, AUTOMATIC, COOLING, HEATING).

4 VENTILATION MODE ICON   
These icons indicate the current ventilation mode (HRV only) (AUTOMATIC, HEAT EXCHANGE, BYPASS).

5 VENTILATION ICON   
The ventilation icon appears when the ventilation is adjusted with the ventilation amount button (HRV only). Simultaneously, the ventilation amount is indicated by the fan speed icon (see 22).

6 AIR CLEANING ICON   
Indicates that the air cleaning unit (option) is operational.

7 AWAY ICON AWAY  
Status of the away function.

ON	AWAY is enabled
FLASHING	AWAY is active
OFF	AWAY is disabled

8 EXTERNAL CONTROL ICON   
Indicates that another controller with higher priority is controlling or disabling your installation.

9 CHANGE-OVER UNDER CENTRALISED CONTROL ICON   
This icon indicates that the change-over of the installation is under centralised control assigned to another indoor unit or optional cool/heat selector connected to the outdoor unit (= master remote controller).

10 DAY OF THE WEEK INDICATOR  
MON TUE WED THU FRI SAT SUN  
Displays the current week day (or the set day when reading or programming the schedule timer).

11 CLOCK DISPLAY   
Indicates the current time (or the action time when reading or programming the schedule timer).

12 MAXIMUM SET TEMPERATURE   $88^{\circ}\text{F}_{\text{max}}$   
The maximum set temperature indicates the maximum set temperature when in limit operation.

13 MINIMUM SET TEMPERATURE   $88^{\circ}\text{F}_{\text{min}}$   
The minimum set temperature indicates the minimum set temperature when in limit operation.

14 SCHEDULE TIMER ICON   
Indicates that the schedule timer is enabled.

15 ACTION ICONS 1 2 3 4 5  
These icons indicate the actions for each day of the schedule timer.

16 OFF ICON OFF  
Indicates that the OFF action is selected when programming the schedule timer.

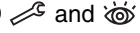
17 INSPECTION REQUIRED   
These icons indicate that inspection is required. Consult your installer.

18 SET TEMPERATURE DISPLAY   $88^{\circ}\text{F}_{\text{min}}$   
This indicates the current set temperature of the installation (not shown in LIMIT operation or in FAN or DRY mode).

19 SETTING SETTING  
Not used, for service purposes only.

20 AIR FLOW DIRECTION ICON   
Indicates the air flow direction (only for installations with motorised air flow flaps).

21 NOT AVAILABLE  NOT AVAILABLE  
NOT AVAILABLE is displayed whenever a non-installed option is addressed or a function is not available.

22 FAN SPEED ICON  AUTO L H HIH FAN  
Indicates the set fan speed.

23 DEFROST/HOTSTART MODE ICON  (STAND BY)  
Indicates that the defrost/hotstart mode is active.

24 AIR FILTER CLEANING TIME ICON   
Indicates the air filter must be cleaned. Refer to the manual of the indoor unit.

25 ELEMENT CLEANING TIME ICON   
Indicates the element must be cleaned (HRV only).

**26 VENTILATION MODE BUTTON** 

The ventilation mode button operates the HRV; refer to the HRV manual for more details.

**27 VENTILATION AMOUNT BUTTON** 

Sets the ventilation amount; refer to the HRV manual for more details.

**28 INSPECTION/TEST OPERATION BUTTON** 

Not used, for service purposes only.

**29 PROGRAMMING BUTTON FUNCTION**

This button is a multi-purpose button.

Depending on the previous manipulations of the user, the programming button can have various functions.

**30 SCHEDULE TIMER BUTTON**

Enables or disables the schedule timer.

**31 TIME ADJUST BUTTON**

Adjusts the clock or, when in programming mode, to adjust the programmed action time. Both buttons have an auto-repeat function.

**32 TEMPERATURE ADJUST BUTTONS**

Adjusts the current setpoint or, when in programming mode, to adjust the programmed setpoint temperature (step = 1°F). Both buttons are also used to adjust the day

of the week.

**33 OPERATION CHANGE/ MIN-MAX BUTTON**

This button is a multi-purpose button. Depending on the previous manipulations of the user, it can have following functions:

- 1 select the operation mode of the installation (FAN, DRY, AUTOMATIC, COOLING, HEATING)
- 2 toggle between minimum temperature and maximum temperature when in limit operation

**34 SETPOINT/LIMIT BUTTON**

Toggles between setpoint, limit operation or OFF (programming mode only).

**35 FAN SPEED BUTTON**

Toggles between L (Low), H (High), HH (very High), AUTO (Automatic).

**36 AIR FLOW DIRECTION ADJUST BUTTON**

Adjusts the air flow direction.





**37 AIR FILTER CLEANING TIME ICON RESET BUTTON** 

Resets the air filter cleaning time icon.

3P166742-1

### 2.7.5 Installation

The kit includes the following parts:

<b>Remote controller</b>	<b>Wood screws</b>
	
<b>Wall plugs</b>	<b>Machine screws</b>
	

#### 1. Remove the upper part of remote controller

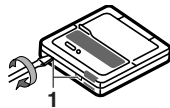

Insert a minus screwdriver into the slots (1) in the lower part of the remote controller (2 places), and remove the upper part of the remote controller.



The PC board is mounted in the upper part of the remote controller. Be careful not to damage the board with the minus screwdriver.

#### 2. Fasten the remote controller

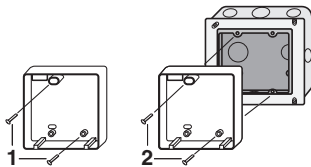

- 1 for exposed mounting, fasten with the two included wood screws (Ø4x30) and plugs.
- 2 for flush-mounting, fasten with the two included machine screws (M4x16).

For the field supplied switch box, use optional accessory KJB111A or KJB211A.



Choose the flattest place possible for the mounting surface. Be careful not to distort the shape of the lower part of the remote controller by overtightening the mounting screws.

### 3. Wire the indoor unit

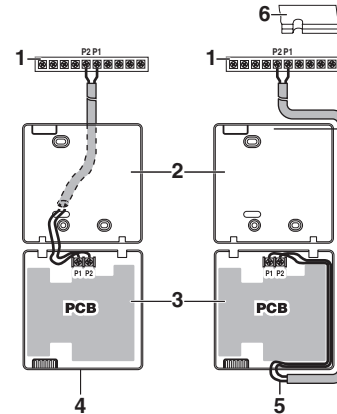

- 1 indoor unit
- 2 lower part of the remote controller
- 3 upper part of the remote controller
- 4 wired from the rear
- 5 wired from the top
- 6 notch the part for the wiring to pass through with nippers

Connect the terminals on top of the upper part of the remote controller (P1, P2), and the terminals of the indoor unit (P1, P2). (P1 and P2 do not have polarity.)

**NOTE**



When wiring, run the wiring away from the power supply wiring in order to avoid receiving electric noise (external noise).

#### Wiring specifications

Wiring type	Size
2 conductor, stranded, non-shielded copper cable / PVC or vinyl jacket	AWG18

**NOTE**



Peel the shield for the part that has to pass through the inside of the remote controller case ( / ).



#### 4. Reattach the upper part of the remote controller



Be careful not to pinch the wiring when attaching.

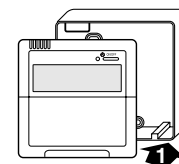

First begin fitting from the clips at the bottom.

**NOTE**



- 1. The switch box and wiring for connection are not included.
- 2. Do not directly touch the PC board with your hand.

### If controlling one indoor unit or one group of indoor units with two remote controllers

Change the MAIN/SUB changeover switch setting as described below.

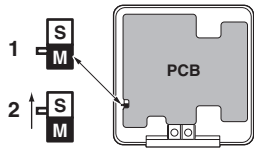

- 1 Main remote controller (factory set)
- 2 Sub remote controller

Set one remote controller to **MAIN** and the other to **SUB**.

**NOTE** 1. If controlling with one remote controller, be sure to set it to **MAIN**.  
 2. Set the remote controller before turning the power supply on.

“88” is displayed for about one minute when the power supply is turned on. During this time the remote controller can not be operated.

### 5. Permission level function

■ If required, you can limit the user action by restrict **FIELD SETTINGS**.

Level	Operable buttons
1	All
2	<ul style="list-style-type: none"> <li>• on/off button</li> <li>• schedule timer button</li> <li>• temperature adjust button</li> <li>• operation change/MIN-MAX button</li> <li>• fan speed button</li> <li>• air flow direction adjust button</li> </ul>
3	<ul style="list-style-type: none"> <li>• on/off button</li> <li>• temperature adjust button</li> <li>• fan speed button</li> </ul>

■ For switching between level 1 permission and the selected level in service, proceed as follows:

- 1 Keep the **FAN SPEED** button pressed,
- 2 and press the 3 other indicated buttons simultaneously while keeping the **FAN SPEED** button pressed.

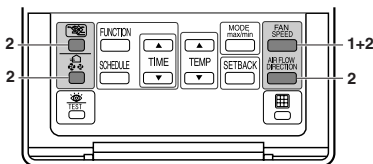

■ If you want to limit the user action on the remote controller to be defined as **SUB**, start with only connecting this controller to the unit. Make sure that this controller is set to **MAIN** (factory set) first, change the permission level to the setting you prefer and only then set the remote controller to **SUB**.

You can now proceed with connecting the remote controller to be defined as **MAIN**.

### 6. Field settings

If optional accessories are mounted on the indoor unit, the indoor unit setting may have to be changed. Refer to the instruction manual for each optional accessory.

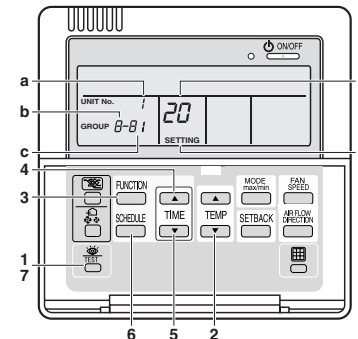

- a Unit No.
- b First Code No.
- c Second Code No.
- d Mode No.
- e Field set mode

### Procedure

1. When in the normal mode, press the **TEST** button for a minimum of four seconds, and the FIELD SET MODE is entered.
2. Select the desired MODE NO. with the “TEMP” button.
3. During group control, when setting by each indoor unit (mode No. 20, 21, 22 and 23 have been selected), push the FUNCTION button and select the INDOOR UNIT NO. to be set. (This operation is unnecessary when setting by group.)
4. Push the **TIME** upper button and select FIRST CODE NO.
5. Push the **TIME** lower button and select the SECOND CODE NO.
6. Push the “SCHEDULE” button once and the present settings are SET.
7. Push the **TEST** button to return to the NORMAL MODE.

### Example

If during group setting and the time to clean the air filter is set to FILTER CONTAMINATION - HEAVY, SET MODE NO. to [10], FIRST CODE NO. to [0], and SECOND CODE NO. to [02].

**NOTE** 1. Setting is carried out in the group mode, however, if the mode number inside the parentheses is selected, indoor units can also be set individually.  
 2. The SECOND CODE No. is set to “01” when shipped from the factory.  
 3. Do not make any settings not given in the table.  
 4. Not displayed if the indoor unit is not equipped with that function.  
 5. When returning to the normal mode, 88 may be displayed in the LCD in order for the remote controller to initialize itself.  
 6. It is not possible to change field settings on the remote controller that is set to **SUB**.

Mode No. Note 1	FIRST CODE NO.	Description of setting	SECOND CODE NO. Note 2						
			01	02	03	04			
10(20)	0	Filter Contamination - Heavy/Light are settings for for spacing of display time to clean air filter: When filter contamination is heavy, display time to clean air filter is halved.	Ultra long life filter	Light	Approx. 10.000 hrs.	Heavy	Approx. 5.000 hrs.	—	—
			Long life filter		Approx. 2.500 hrs.		Approx. 1.250 hrs.		
			Standard filter		Approx. 200 hrs.		Approx. 100 hrs.		
	1	Long-life filter type has setting for filter-change indication time. Change setting when ultra-long filter is installed.	Long-life filter	Ultra-long life filter	—	—			
2	Thermostat sensor in remote controller	Use	Not use	—	—				
3	Display (or not display) time to clean air filter count.	Display	Do not display	—	—				
12(22)	1	ON/OFF input from outside: Setting for when forced ON/OFF is to be operated from outside.	Forced OFF	ON/OFF operation	—	—			
	2	Thermostat differential changeover is a setting for when using remote sensor.	2°F	1°F	—	—			
13(23)	3	Selection of air flow function: Setting for when using a decoration panel for outlet.	Equipped	Not equipped	—	—			
	4	Air flow direction range setting.	Upper	Normal	Lower	—			
15(25)	3	Drain pump operation including humidifying.	Equipped	Not equipped	—	—			
1b	0	Permission level setting	Level 2	Level 3	—	—			
	1	Away Function	Not permitted	Permitted	—	—			
	2	Thermostat sensor in remote controller is only for ILimit oOperation and aAway fFunction.	Use	Not use	—	—			

3P166742-2

## 2.8 DCS601C71 intelligent Touch Controller

### 2.8.1 Features

Central remote controller offering more advanced functionality and easier operation than the previous DSC302C71 controller.

Up to 64 groups of indoor units may be connected to 1 unit of this controller.



This controller aims to be a product positioned between the current central controlling device (central controller DCS302C71) and the controller D-BIPS for large scale buildings (in both the viewpoints of application area and functional grade), and is a central controller most suitable for middle and small size buildings.

< Products Features >

#### 1. High Level Functions

- Annual schedule control
- Electricity proportional distribution function (option)
- Air net function (DCS601C71 only)

#### 2. Easy Operation

- Color liquid crystal
- Icon display
- Touch panel application
- Air conditioner name and zone name input available

#### 3. D-III NET × 1 line (64 units)

#### 4. Saving expenses

- Controlling personnel not required (saving control expenses)
- Energy saving schedule
- Functions equal to those of a compact monitor panel

(V2318)

#### ■ Operation Menu

intelligent Touch Controller is capable of starting/stopping operations by group or zone. Collective starting/stopping is also available.

#### ■ Air Conditioner Detail Setup

Temperature setting, switching between temperature control modes, switching of speed and direction of wind, and remote control mode setting are available by the group, zone, or all units collectively.

#### ■ Monitoring of Various Information on Indoor Units

Information on operation such as the operation mode and temperature setting of the indoor units, maintenance information including the filter or element cleaning sign, and troubleshooting information such as error codes can be displayed by the group or zone.

#### ■ Diversified Operation Modes

Operation can be controlled both with the main unit and the remote control to provide diversified operation management. Setting with the main unit allows the following remote control settings by group, zone, or all units collectively:

- |                           |                           |                           |
|---------------------------|---------------------------|---------------------------|
| 1. Start/Stop             | 2. Operation Mode         | 3. Temperature Setting    |
| •Remote control Inhibited | •Remote control Inhibited | •Remote control Inhibited |
| •Remote control Permitted | •Remote control Permitted | •Remote control Permitted |
| •Priority                 |                           |                           |

#### ■ Zone Control Simplifying Complicated Setting Operations

Up to 64 groups can be controlled with the intelligent Touch Controller.

There is a function to allow collective setting for all groups is also available. To eliminate entering the same setting for each group, multiple groups can be consolidated into one zone that can then be registered for uniform settings of the following functions:

- Start/stop
- Setting of direction and fan speed
- Temperature setting
- Disabling/enabling the remote control
- Switching between operation modes

#### ■ Detailed Scheduled Operation Control

The intelligent Touch Controller allows detailed scheduled operation by the group, zone, or all units collectively. Up to 8 options for an annual schedule can be set. Each schedule can include four types of plans : for Monday through Sunday, Special Day 1~10, Special Days 1 and Special Days 2. Each of the plans allows setting of up to 16 operations.

■ **Handy Automated Control**

The intelligent Touch Controller offers the following automated controls:

- Change Over Settings : automatically switches between cooling and heating according to the room temperature.
- Temperature Limit Setting : prevents the temperature from rising too high or too low in unmanned rooms.
- Heating Optimization Settings : stops uncomfortable hot air from blowing when the thermostat is off.

**2.8.2 System Overview**

This intelligent Touch Controller is capable of controlling/monitoring up to 64 **groups of indoor units** (hereafter “groups”).

The main functions of the intelligent Touch Controller include:

1. Collective starting/stopping of operation of the indoor units connected to the intelligent Touch Controller.
2. Starting/stopping of operation, temperature setting, switching between temperature control modes and enabling/disabling of operation with the hand-held remote control by **zone** or **group**.
3. Scheduling by **zone** or **group**.
4. Monitoring of the operation status by **zone** or **group**.
5. Display of the air conditioner operation history.
6. Compulsory contact stop input from the central monitoring panel (non-voltage, normally-open contact).
7. Control and Monitoring of air conditioner with personal computer by the Controller (with the optional DCS004A71).

\* A **group of indoor units** include:

- ① One indoor unit without a remote control.
- ② One indoor unit controlled with one or two remote controls.

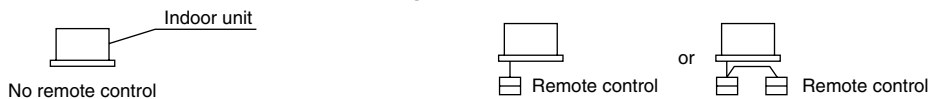

- ③ Up to 16 indoor units controlled with one or two remote controls.



\* **Zone** control with the intelligent Touch Controller

\* **Zone** control, which allows collective settings for more than one group, is available with the intelligent Touch Controller, which facilitates the setting operations.

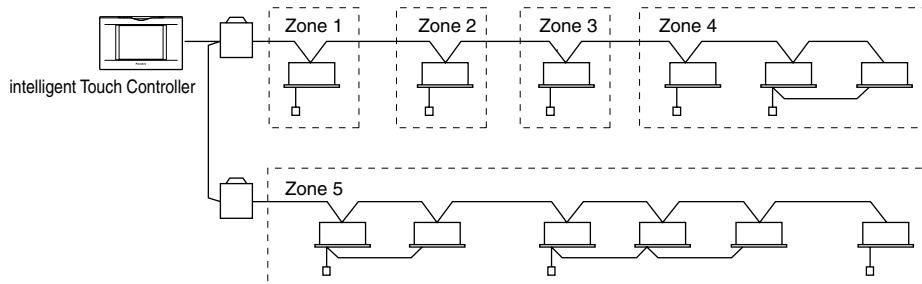

- One setting makes the same setting for all of the units in one zone.
- Up to 128 zones can be set with one intelligent Touch Controller.  
(The maximum number of groups in one zone is 64.)
- Groups can be zoned at will with the intelligent Touch Controller.
- Units in one group can be divided into more than one zone.

3P073677-15T



### 2.8.3 Options

Connecting Unification adaptor allows using the contact for normal and abnormal operation signal and collective start/stop with a contact. For details, contact the vendor you purchased the product from.

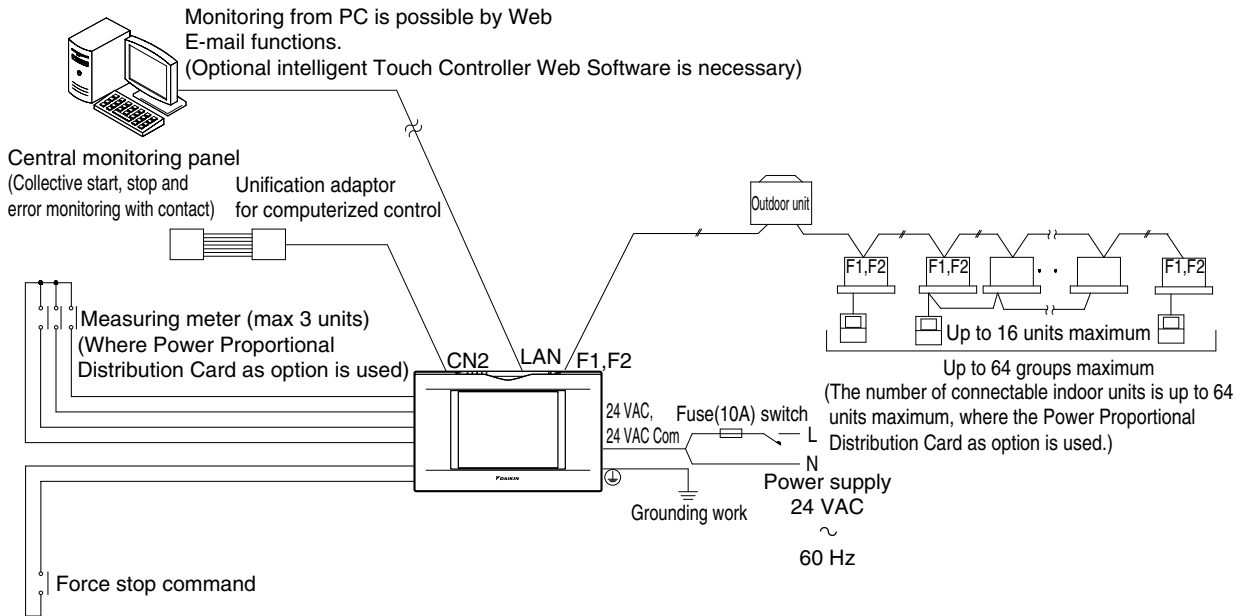

3P073677-15T

### 2.8.4 Specification

#### Specification

Power	AC24V 50/60Hz
Power consumption	10 W maximum
Force stop input	Normally-open contact Contact current approximately 10 mA
Size	9-1/16x5-25/32x4-7/32 (WxHxD)
Mass	2 lb 10 oz

#### Dimension

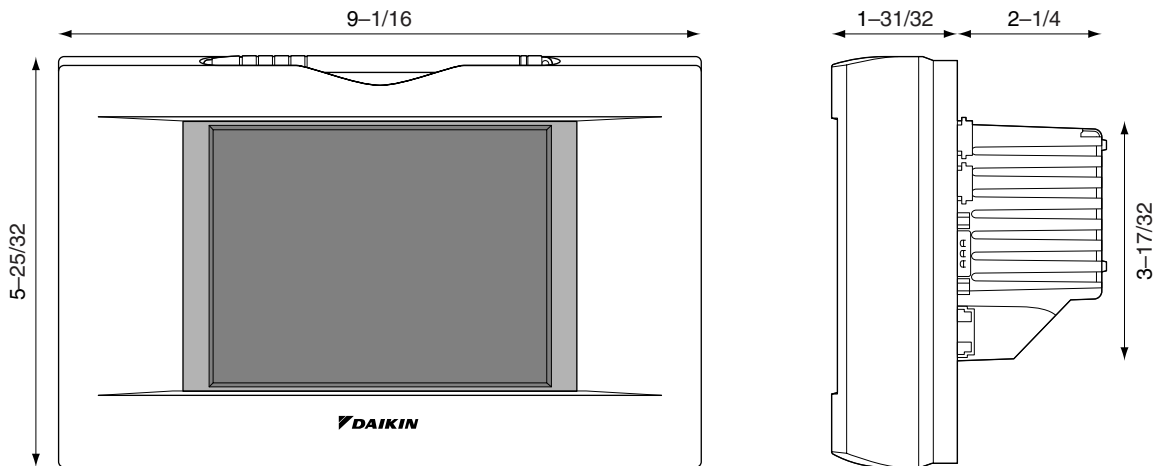

The specification and appearance of the product may be modified for improvement without prior notice.

3P073677-15T

### 2.8.5 Part Names and Functions

#### Front and Side View



**PCMCIA Card Slot**

Used when updating the intelligent Touch Controller software to a newer version.



**Color LCD with Touch Panel**

Provides a display for monitoring and operation.  
Be sure to use the touch pen provided for operation.

**Touch Pen**

Use the touch pen for operation. Be sure to use the touch pen for operation. Use caution not to lose the touch pen.  
(When the pen is lost, contact the dealer you purchased the product from.)

**NOTE**

- Be sure to use the touch pen for operation of the touch panel of the intelligent Touch Controller. Operating with an object other than the touch pen provided may cause damage and failure.

3P073677-15T

#### Terminals on the Back of intelligent Touch Controller

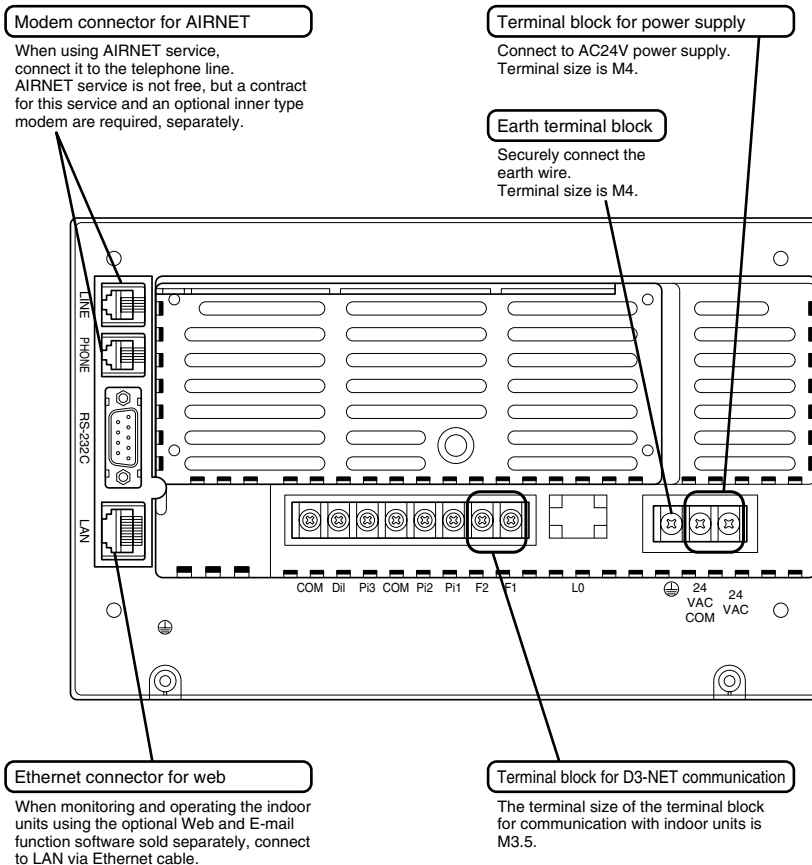

## 2.8.6 Monitoring Screen Labels and Functions

**Contents of the List Currently Displayed**  
 •When Group List is displayed  
 “Zone: Zone Name”  
 •When Zone List is displayed  
 “Zone List Display”

**Zone/Group Currently Displayed**  
 The name of the zone/group currently selected is highlighted in blue flame.

**Display Mode Selection**  
 Select between Zone and Group.

**System Condition Displayed Domain**  
 Domain displaying system condition (Compulsory Stop etc.)

**Filter/Element Sign**  
 Displayed when there is any air conditioner showing a filter or element sign in the zone or the group.

**Zone/Group Name**  
 Set the names in the Group Registration or Zone Registration in the System Setup Mode.

**Target of Automatic Control**  
 Displayed when there is any air conditioner with the registration of scheduled in the zone or in the group.

**Description of Zone/Group**  
 Set the names in the Group Registration or Zone Registration in the System Setup Mode.

**Monitoring Screen Legend**  
 Pressing the “?” button shows more detailed legend.

**Information on Zone/Group Currently Displayed**  
 Generally, the temperature setting and the operation mode are displayed. If any error occurs in the air conditioner, the error code is displayed.

**Displayed Abnormality in Air Conditioner or Communication**  
 Blue triangular mark shows communication abnormality in air conditioner.  
 Yellow triangular mark shows abnormality in air conditioner.

**Button to Switch to the System Setup Mode**  
 Use this button for settings including the time, group, zone and schedule.

**Display for Collective Monitoring of Air Conditioners Connected to intelligent Touch Controller**  
 When operation is normal and any air conditioner is in operation:  
 Red/Normal  
 When operation is normal and all air conditioners are in stoppage:  
 Green/Normal  
 When there is any air conditioner generating an error:  
 Yellow/Abnormal  
 When there is any air conditioner with communication error:  
 Blue/Abnormal  
 (Change in color of Start/Stop is possible by Iconcolor Settings in System Settings.)

**Start All Button**  
 Button to collectively start all the air conditioners connected to intelligent Touch Controller.

**Stop All Button**  
 Button to collectively stop all the air conditioners connected to intelligent Touch Controller.

**Display Mode Selection**  
 Select the mode among icon/list/detailed icon. (Displayed is List in the right figure. List display in P469. Detailed icon display is P468.)

**Group/Zone Start Button**  
 Button to start operation of the group/zone selected.

**Group/Zone Stop Button**  
 Button to stop operation of the group/zone selected.

**Group/Zone Set Button**  
 Makes settings (temperature setting, temperature control mode, etc.) and display of the group/zone selected.

**Group/Zone Prop Button**  
 Detailed display of the group/zone selected

**Current Time Display**  
 Shows the current date and time.

**Lock Setting/Cancel Button**  
 Displays possibility of monitor operation.

**Scroll Buttons**  
 Up/Down scroll button used when monitoring zone/group which are not currently displayed.  
 Left/Right scroll button used when monitoring temperature and errors etc. Which are not currently displayed.

EM05A058

Icons

**Contents of the List Currently Displayed**  
 •When Group List is displayed "Zone: Zone Name"  
 •When Zone List is displayed "Zone List Display"

**Filter/Element Sign**  
 Displayed when there is any air conditioner showing a filter or element sign in the zone or the group.

**Zone/Group Name**  
 Set the names in the Group Registration or Zone Registration in the System Setup Mode.

**Target of Automatic Control**  
 Displayed when there is any air conditioner with the registration of scheduled in the zone or in the group.

**Displayed Abnormality in Air Conditioner or Communication**  
 Blue triangular mark shows communication abnormality in air conditioner.  
 Yellow triangular mark shows abnormality in air conditioner.

**Monitoring Screen Legend**  
 Pressing the "?" button shows more detailed legend.

**Zone/Group Currently Displayed**  
 The name of the zone/group currently selected is highlighted in blue frame.

**System Condition Displayed Domain**  
 Domain displaying system condition (Compulsory Stop etc.).

**Display Mode Selection**  
 Press the button and a display change between Zone and Group.

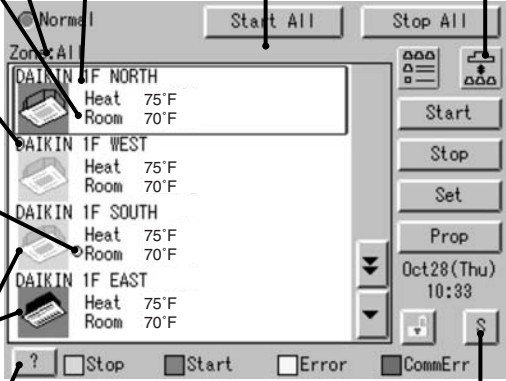

**Display for Collective Monitoring of Air Conditioners Connected to intelligent Touch Controller**  
 When operation is normal and any air conditioner is in operation: Red/Normal  
 When operation is normal and all air conditioners are in stoppage: Green/Normal  
 When there is any air conditioner generating an error: Yellow/Abnormal  
 When there is any air conditioner with communication error: Blue/Abnormal  
 Change in color of Start/Stop is possible by Iconcolor Settings in System Settings.

**Start All Button**  
 Button to collectively start all the air conditioners connected to intelligent Touch Controller.

**Stop All Button**  
 Button to collectively stop all the air conditioners connected to intelligent Touch Controller.

**Display Mode Selection**  
 Select the mode among icon/list/detailed icon.  
 (Displayed in List in the right figure.)  
 (List display is P469)  
 (Icon display is P467.)

**Group/Zone Start Button**  
 Button to start operation of the group/zone selected.

**Group/Zone Stop Button**  
 Button to stop operation of the group/zone selected.

**Group/Zone Set Button**  
 Makes settings (temperature setting, temperature control mode, etc.) and display of the group/zone selected.

**Group/Zone Prop Button**  
 Detailed display of the group/zone selected

**Current Time Display**  
 Shows the current date and time.

**Lock Setting/Cancel Button**  
 Displays possibility of monitor operation.

**Scroll Buttons**  
 Up/Down scroll button used when monitoring zone/group which are not currently displayed.  
 Left/Right scroll button used when monitoring temperature and errors etc. Which are not currently displayed.

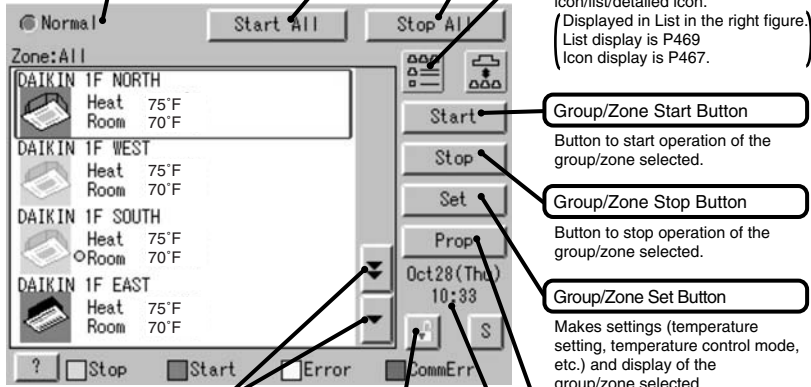

**Lists:**

**Contents of the List Currently Displayed**

- When Group List is displayed "Zone: Zone Name"
- When Zone List is displayed "Zone List"

**Zone/Group Currently Displayed**

The name of the zone/group currently selected is highlighted in light-blue.

**Display Mode Selection**

Press the button and display change between Zone and Group.

**System Condition Displayed Domain**

Domain displaying system condition (Compulsory Stop etc.)

**Zone/Group Name**

Set the names in the Group Registration or Zone Registration in the System Setup Mode.

**Target of Automatic Control**

Displayed when there is any air conditioner with the registration scheduled in the zone or in the group.

**Filter/Element Sign**

Displayed when there is any air conditioner showing a filter or element sign in the zone or the group.

**Monitoring Screen Legend**

Pressing the "?" button shows more detailed legend.

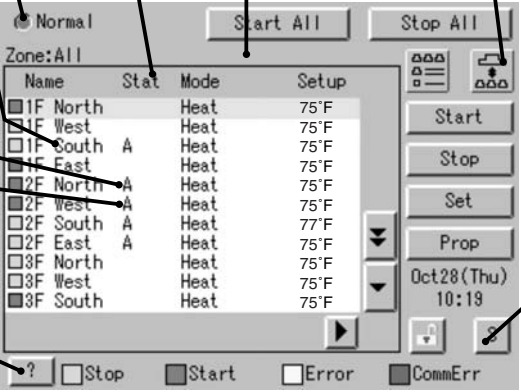

**Display for Collective Monitoring of Air Conditioners Connected to intelligent Touch Controller**

When operation is normal and any air conditioner is in operation:  
Red/Normal

When operation is normal and all air conditioners are in stoppage:  
Green/Normal

When there is any air conditioner generating an error:  
Yellow/Abnormal

When there is any air conditioner with communication error:  
Blue/Abnormal

(Change in color of Start/Stop is possible by Iconcolor Settings in System Settings.)

**Start All Button**

Button to collectively start all the air conditioners connected to intelligent Touch Controller.

**Stop All Button**

Button to collectively stop all the air conditioners connected to intelligent Touch Controller.

**Display Mode Selection**

Select the mode among icon/list/detailed icon. (Displayed in List in the right figure.) Icon display is P467. Detailed icon display is P468.

**Group/Zone Start Button**

Button to start operation of the group/zone selected.

**Group/Zone Stop Button**

Button to stop operation of the group/zone selected.

**Group/Zone Set Button**

Makes settings (temperature setting, temperature control mode, etc.) and display of the group/zone selected.

**Group/Zone Prop Button**

Detailed display of the group/zone selected

**Current Time Display**

Shows the current date and time.

**Lock Setting/Cancel Button**

Displays possibility of monitor operation.

**Scroll Buttons**

Up/Down scroll button used when monitoring zone/group which are not currently displayed.  
Left/Right scroll button used when monitoring temperature and errors etc.  
Which are not currently displayed.

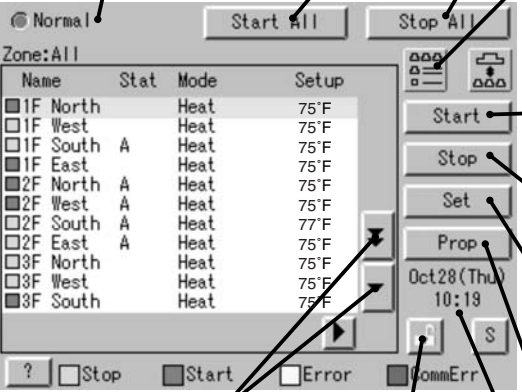

### 2.8.7 Electrical Wiring Connection

When wiring, cut off the power supply (using a local switch) and do not apply power until all work has been finished.

**Wiring for power supply and Connecting wiring for DIII-NET communication of indoor units**

In order to perform centralized control of indoor units using this controller, connect the power wiring to terminals 24VAC and 24VAC COM, earth wire to earth terminal and connecting wiring for DIII-NET communication of air-conditioner (indoor unit and outdoor unit) to terminals F1 and F2 respectively as shown in the sketch below.

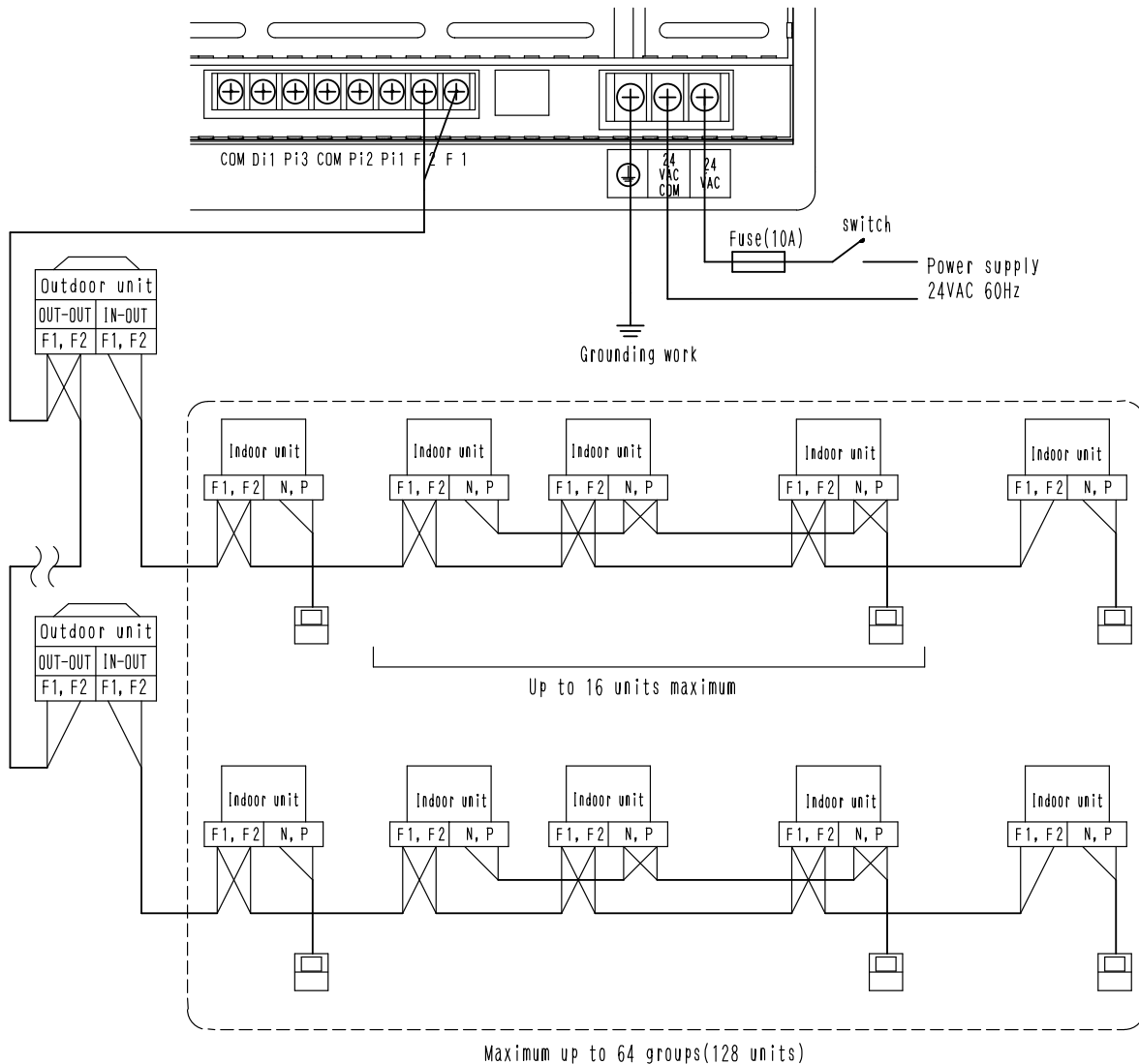

Power cable wiring	1, 2.5 mm <sup>2</sup>
Fuse	10A
Connecting wiring for DIII- NET communication of indoor and outdoor units	0, 75 - 1, 25 mm <sup>2</sup> vinyl cord or cable with sheath (2 wire) ---Up to 1000 m maximum (wiring length -- up to 2000 m maximum) (When shield cable is used, the wiring length is available up to 1500m.) For the type of electric wire, refer to the design guide.

- << CAUTION >>
- Don't fail to perform installation of Grounding work. Don't connect the grounding wire to any of gas pipe, city water pipe, lightning rod, and telephone grounding wire.
  - Don't turn ON the power supply (front switch) until all the works are complete.
  - The connecting wiring for communication of indoor and outdoor units is a connecting wiring for the control. Don't clamp these cables together with high voltage cables. Failure to observe this instruction would cause control error.
  - Don't connect the power cable to F1, F2 terminal blocks. Wrong connection to these terminal blocks could result in damage and burning of the centralized control devices and of the electric parts of the indoor and outdoor units. This is very hazardous. Check each wired cable once more before turning ON the power switch.

**Wiring for force stop input**

In order to stop the air-conditioner through force stop input, connect the wiring for force stop input to the terminals Di1 and COM as shown in the sketch below.

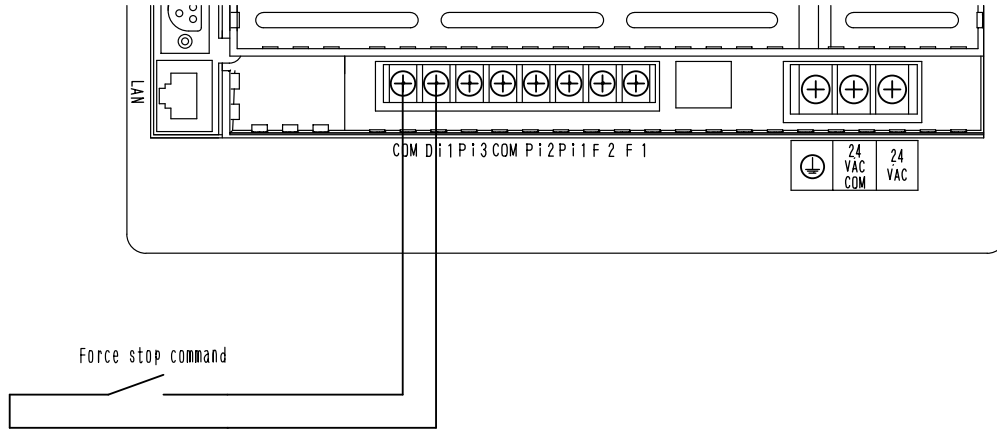

<p>Wiring for force stop input</p>	<ul style="list-style-type: none"> <li>• 0.75 - 1.25 mm<sup>2</sup> vinyl cord or cable with sheath (2 wire) -- up to 150m maximum</li> <li>• When FORCE-STOP INPUT is kept ON, the indoor units connected thereto are unable to be operated because they are force-stopped.</li> <li>• Use a contact which can guarantee minimum application load DC16V and 10mA.</li> <li>• Use an instantaneous contact of 200msec or more in current feed time, where required.</li> </ul>
------------------------------------	--

◀ CAUTION ▶

- Don't clamp these cables together with high voltage cables. Failure to observe this instruction would cause control error.
- Terminals COM are inter-connected. Connecting to either one is allowed, but the number of cables connectable to one terminal is limited to 2 pieces.
- Don't connect the power cable to Di, COM terminal blocks. Wrong connection to these terminal blocks could result in damage and burning of the centralized control devices and of the electric parts of the indoor and outdoor units. This is very hazardous. Check each wired cable once more before turning ON the power switch.

Connection to public telephone line

Connect to the telephone line in order to monitor the air-conditioner via AIRNET service. Connect to modular cable from the public telephone line to the upper connector with a stamping of LINE, and connect the modular cable of the telephone to the lower connector with a stamping of PHONE, as shown in the sketch below.

< CAUTION >

- Don't clamp these cables together with high voltage cables. Failure to observe this instruction would cause control error.
- When using AIRNET service, it is necessary to use a separate modem specified by us and enter into Maintenance Agreement with charge.

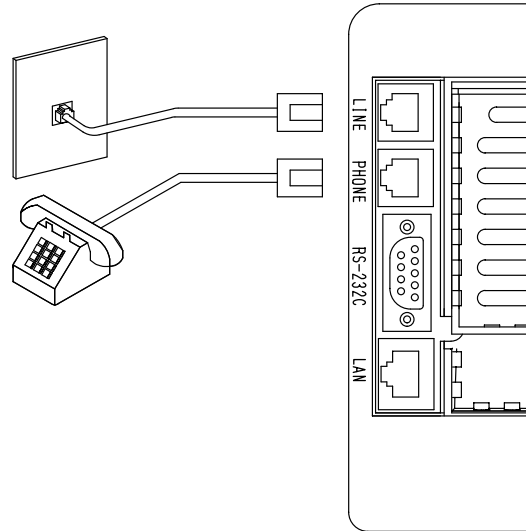

Connection to LAN

In order to monitor/control the air-conditioner using optional Web and E-mail function software sold separately, use a UTP cable to connect to LAN. Connect the UTP cable to the Ethernet connector with a stamping of LAN.

< CAUTION >

- Don't clamp these cables together with high voltage cables. Failure to observe this instruction would cause control error.
- For connecting to LAN, consult with the network system administrator.

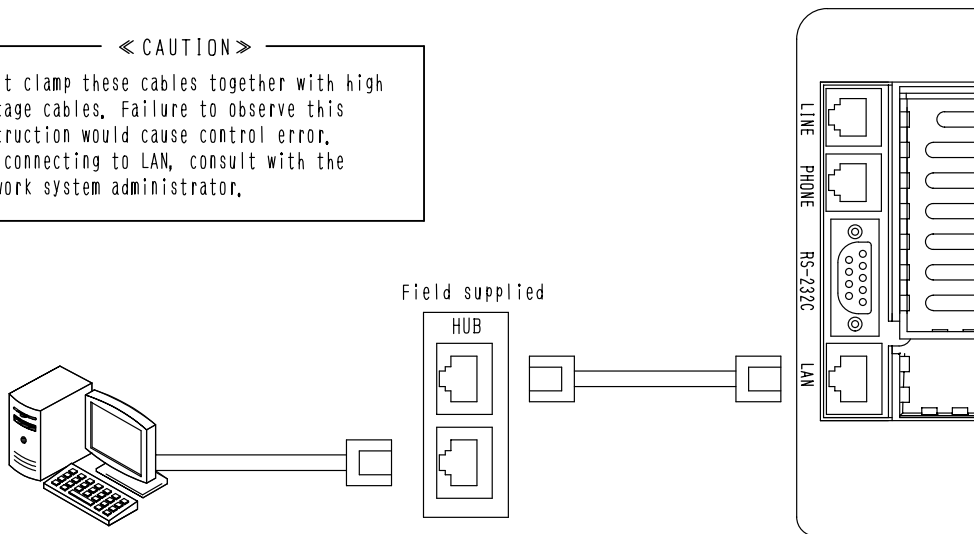



**Modem connection**

Connect to the telephone line in order to monitor the air-conditioner via AIRNET service. Connect to modular cable from the public telephone line to the upper connector with a stamping of LINE, and connect the modular cable of the telephone to the lower connector with a stamping of PHONE, as shown in the sketch below.

**< CAUTION >**

- Don't clamp these cables together with high voltage cables. Failure to observe this instruction would cause control error,
- When using AIRNET service, it is necessary to use a separate modem specified by us and enter into Maintenance Agreement with charge,

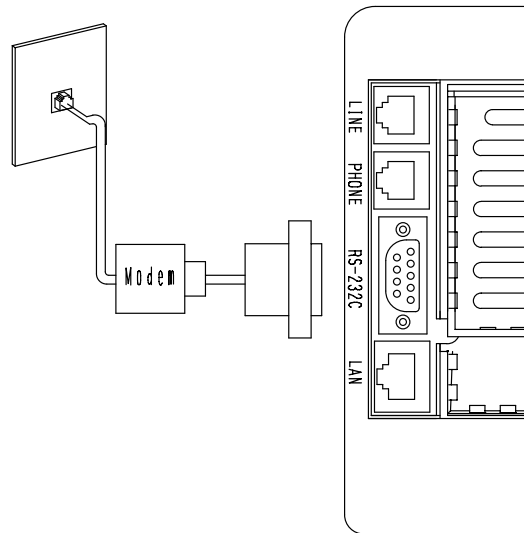

**Connection for Unification Adaptor**

In order to perform total start and stop/situation monitoring from central supervisory board, etc., connect a Unification Adaptor sold separately. As shown in the sketch below, open the controller and connect the cable from the Unification Adaptor to CN2 connector located on the printed board on the lower case. If you route the cable in the cable guide groove on the lower case, you can make a smart connection without any slack of the cable.

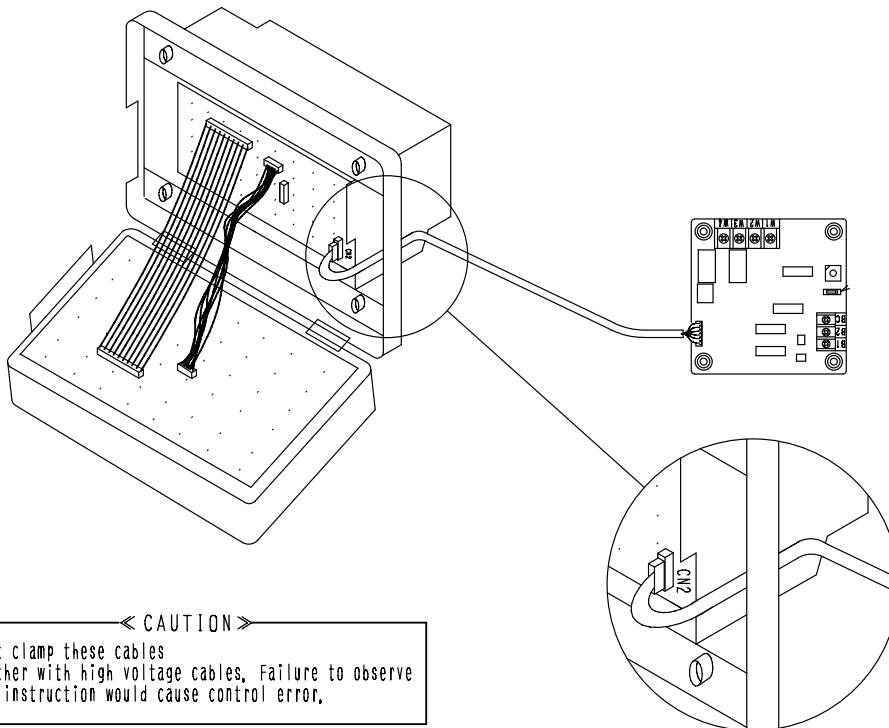

**< CAUTION >**

- Don't clamp these cables together with high voltage cables, Failure to observe this instruction would cause control error,

## 2.8.8 DCS004A71 Web Software for the *intelligent Touch Controller*

---

### Functions and Outline

This software enables you to operate and monitor air conditioners linked to the intelligent Touch Controller on your Windows PC, which is connected to the intelligent Touch Controller and the Ethernet communication (LAN).

\* The intelligent Touch Controller software integrates with your computer, allowing you to operate and monitor the air conditioners.

A mail server is incorporated to alert you if a linked air-conditioner malfunctions by transmitting emails to a pre-assigned address.

For further information, contact our sales representatives.

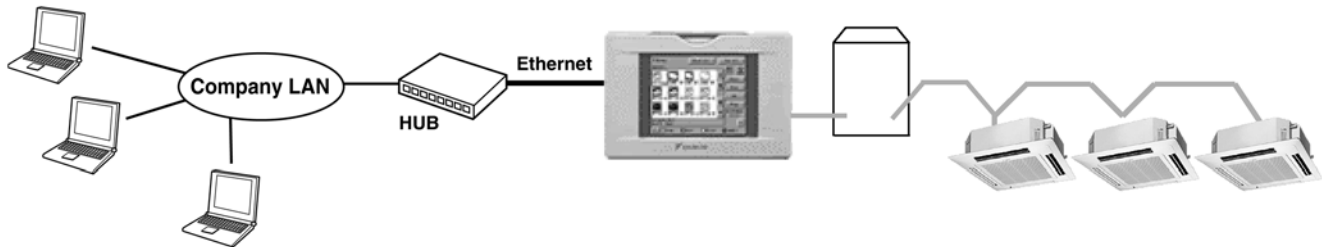

### Web Interface of the intelligent Touch Controller

#### Permissions for Login Names

There are two categories of login users: A **General User** can perform basic operations via the web interface and an **Administrator** can set up the system and change system settings.

#### Two Display Modes

You can select the display mode from two modes during login process: **Basic** mode provides a simple and easy-to-use interface, and **Advanced** mode allows advanced setting options.

#### Start/Stop Operation

Start or stop all the devices in a group, a zone, or multiple zones simultaneously.

#### Advanced Settings for Air Conditioners

You can set temperature, operation modes, direction of air flow, air volume, and remote controller mode of all devices in a group, a zone, or multiple zones.

#### Various Operation Modes

You can operate devices from a web interface, the intelligent Touch Controller console, or a local remote controller. The Administrator can permit or prohibit remote controller operations in a specified group or zone using the web interface.

#### User Administration

The Administrator can register or delete General Users who can operate air conditioners via the web interface, and set/change his/her own password and those of general users.

#### Scheduling Function

The Administrator can schedule operations for a specific group or zone. A weekly schedule plus 10 extra schedules can be created.

EM04A059

### 3. Adaptors

#### 3.1 KRCS01-1 Remote Sensor

The built-in temperature control thermistor of the indoor unit is mounted in the intake port of the main body. Some differences can occur between the temperature setting of the built-in thermistor and the actual indoor temperature. In such cases, remove the thermistor from the indoor unit and remount it near the living area so that the remote sensor can sense the temperature of the living area.

#### Components

The kit contains the following components:

- Remote sensor unit
- Extension wiring
- Two Mounting Screws
- (M4×16)
- Round Crimp Type Terminal
- Two Tie Wraps
- Double-Sided Tape

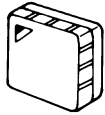

(Height×width×depth)  
2 3/8 × 1 15/16 × 9/16

Color of finish: Light ivory

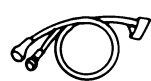

(VIDT×2 AWG 18  
length 39 ft)

(V0280)

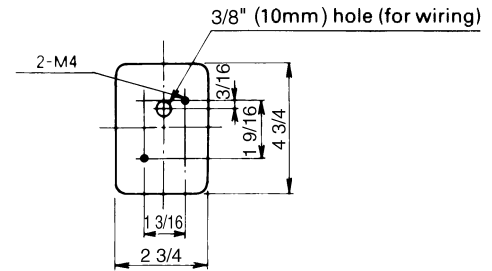

Metal plate hole to be drilled locally (V0283)

#### Mounting Procedure

##### ■ Wall Mounting

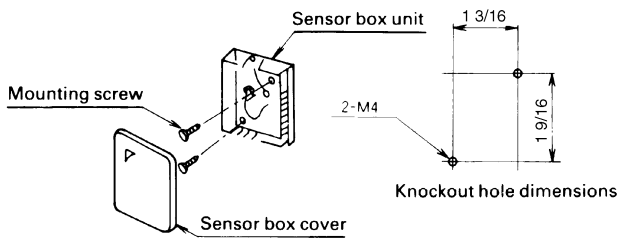

(V0281)

##### ■ Embedded Wiring

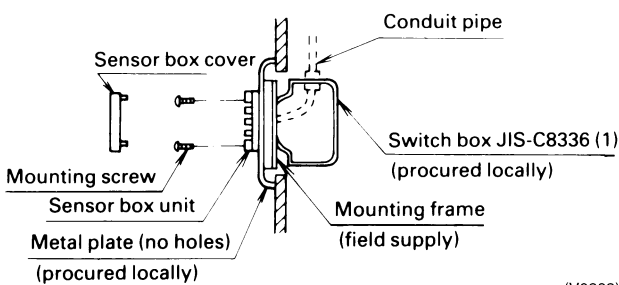

(V0282)

- Drill holes in the metal plate (procured locally) for mounting the sensor box unit, as shown in upper right diagram.
- Do not plug the air holes in the sensor box unit.

#### Wiring Procedure

Use the extension wiring provided to wire between the remote sensor and indoor unit control unit.

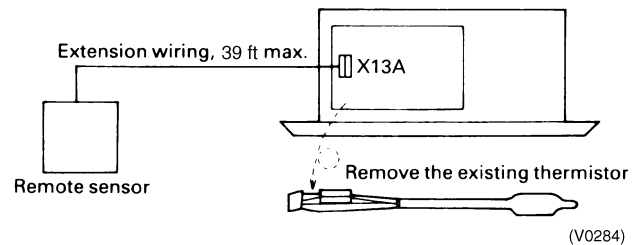

(V0284)

- Remove the unneeded existing thermistor and use the extension wiring to connect the indoor unit's electronic control unit.

#### Note:

When installing extension wiring, avoid noise and power line interferences that hinder operation. Ensure connections/contacts are not loose or they can create inaccurate temperatures and faulty installation.

- **When using the remote sensor, change the thermostat settings using the remote controller.**
- Using the remote controller, change to the field setting mode, select mode No.12, set the setting switch No. to 2, and then set the setting position No. to 02.

### 3.2 DTA104A 53/ 61/ 62 Required Outdoor Unit External Control Adaptor Must be installed on Indoor Units

**Accessories** Check the following accessories are included in the kit before the installation.

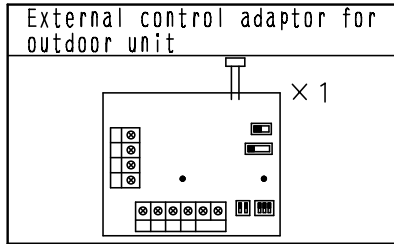

PCB support	× 4
Clamp	× 3
Installation manual	× 8

- NOTES**
- The kit type (DTA104A61・51 type, DTA104A62・52 type) varies according to air conditioner model.
  - The installation plate and box for adaptor PCB are required with the following air conditioner models.  
 FXFQ ..... KRP1C98

## 1 General description of system

With the external control adaptor, outdoor units are controlled as follows.  
 1. Operation mode (COOL/HEAT/FAN) is switched simultaneously for more than one outdoor unit.

- If switching operation mode by indoor unit remote controller or COOL/HEAT selector.

- External control adaptor for outdoor unit
- Indoor unit remote controller

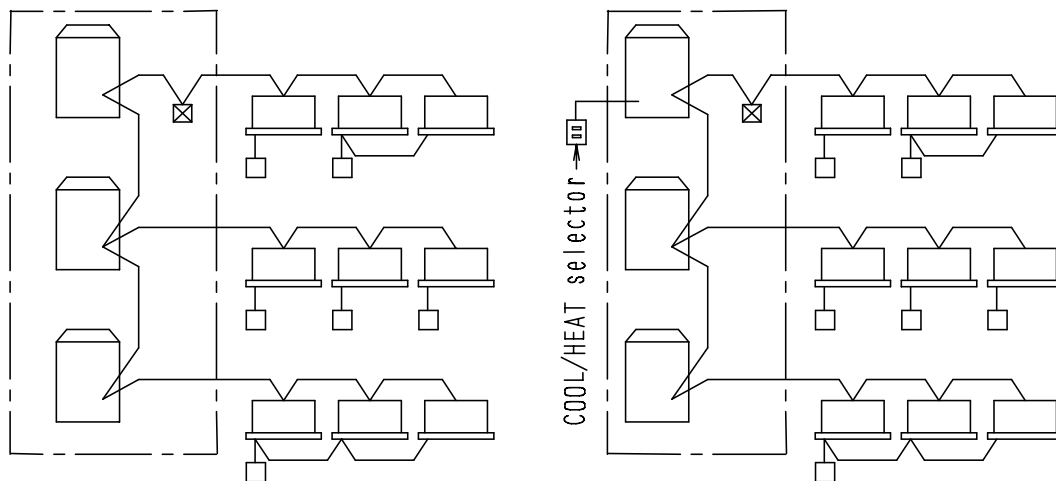

You can simultaneously switch operation mode for outdoor units in [ ] .

C:1PA63164D-1

2. Demand control and low-noise control are executed simultaneously for more than one outdoor unit.

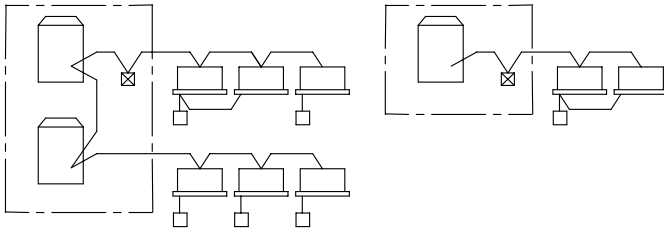

Demand control and low-noise control are executed simultaneously for outdoor units in [ ]

## 2 Names of parts and functions

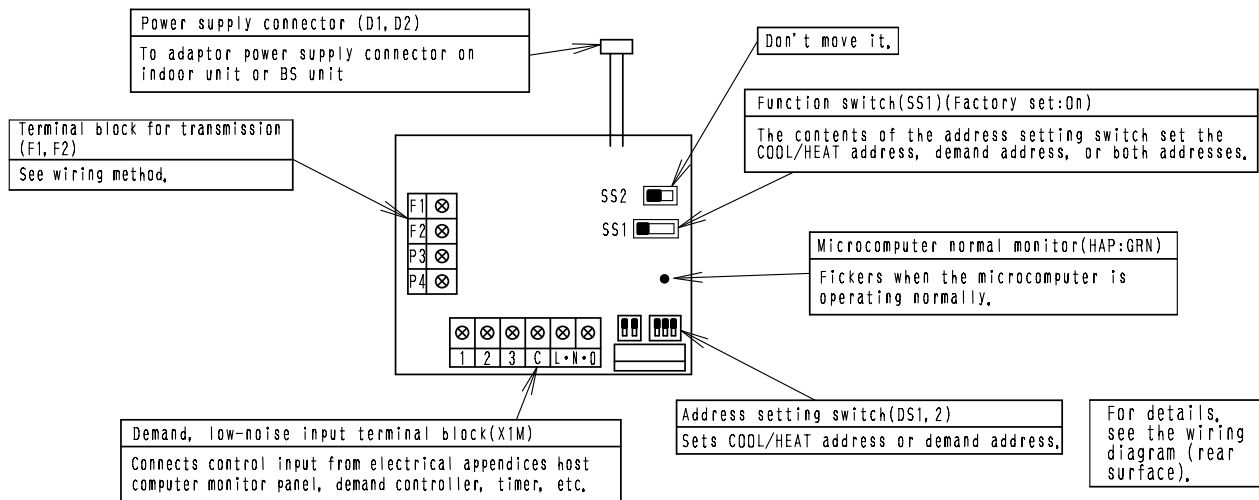

C:1PA63164D-2

### 3.3 DTA109A51 DIII NET Expander Adaptor

**Accessories** Check the following accessories are included in the kit before the installation

Adaptor	× 1
PCB support	× 4
Clamp	× 3
Installation Manual	× 1

**NOTE** This adaptor does not apply to salt damage resistance.

#### 1 General description of system

The adaptor allows easy system expansion as long as restrictions are observed.

1. The below systems can be controlled on the Super Wiring System when using the adaptor.

(1) Up to 1024 units can be centrally controlled in 64 different groups.  
 (With 2 central remote controllers, up to 1024 units can be controlled in 128 groups.)

Restrictions on the number of units that can be connected to the Super Wiring System apply to each adaptor.

The adaptor

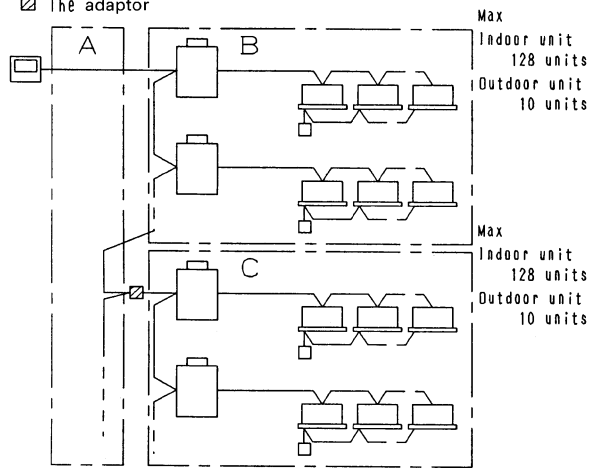

A maximum of 128 indoor units and 10 outdoor units can be connected in each group B and C.

(2) Wiring restrictions (max. length: 3280ft, total wiring length: 6560ft, max. number of branches: 16) apply to each adaptor.

The adaptor

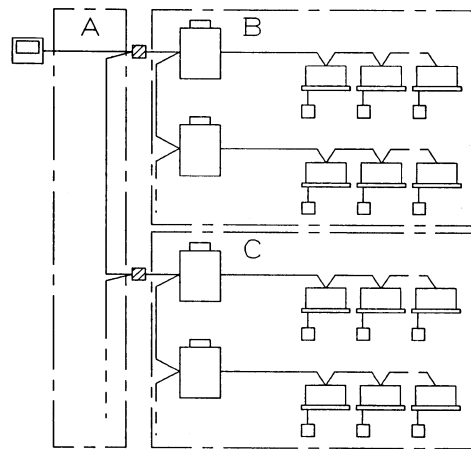

Each group A, B and C can have a maximum wiring length of 3280ft, total wiring length of 6560ft and a maximum 16 branches.

(V0285)

(3) Setups risky for centralized control systems are possible.

**Conventional System** Misswiring such as apply 208-230V to circuits could possibly shut down the entire system.

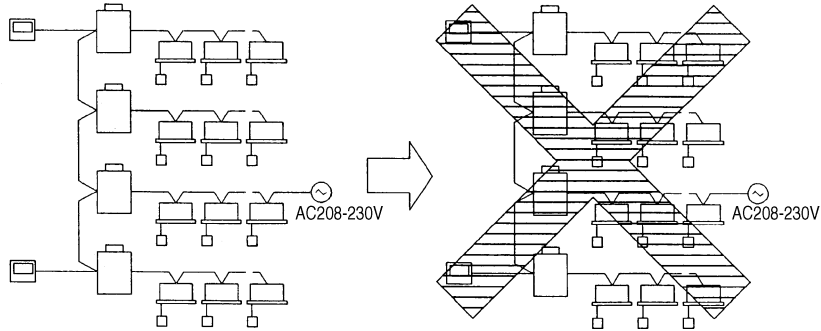

**With the adaptor** Should trouble occur, only units below the adaptor are shut down. Thus, it is possible to avoid a total system shutdown.

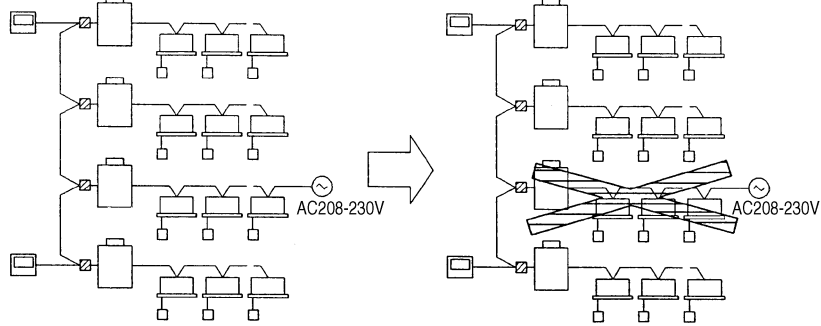

**Names of parts and functions**

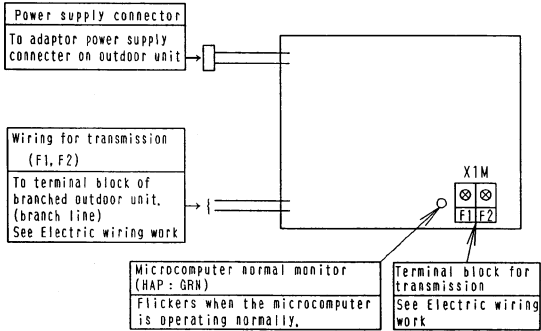

(V0286)

### 3 Electric wiring work

- (1) Connect the wire from the adaptor to the adaptor power connector on the outdoor unit's PC board.  
(For connector Nos, see the electric wiring diagrams for the indoor and function units.)
- (2) Connect transmission wires between outdoor units (Outdoor-Outdoor terminal board).
- (3) Wire transmission wires to terminal boards as shown below.

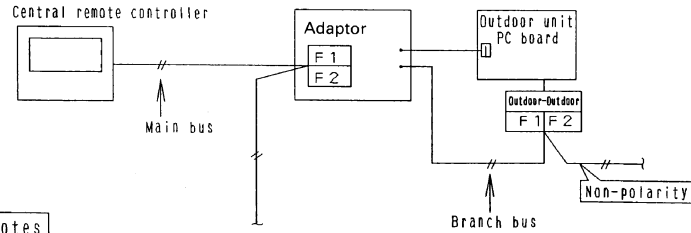

#### Notes

- (Transmission wiring specifications)
  - AWG 18 or 16 sheathed wire (2 wire).
- (Transmission wiring length)
  - Observe the following limits on transmission wires. The limits apply to each adaptor. If you exceed the limits, it may cause malfunction.
    - (Total length : 6560 ft)
    - (Max. length : 3280 ft)
    - (Max. number of branches : 16)
  - At least one outdoor unit and one optional controller for centralized control are required for every main bus and branch bus.
  - Up to 8 adaptors can be connected in one system.
  - Do not locate adaptors downstream of other adaptors (i. e. : on a branch bus).
  - If not used with a central control device, the expander adaptor cannot be used with the schedule timer (DST301B61).
  - The external control adaptor for outdoor units controls group cooling and demand for each adaptor. (Anything beyond the expansion control falls outside the control domain.)
  - Do not turn the system ON/OFF rapidly from the optional controller for centralized control. This can cause temporary erroneous displays.
  - Sequential starts is controlled by each expander adaptor.

### 4 Wiring example

System with more than 10 outdoor units.

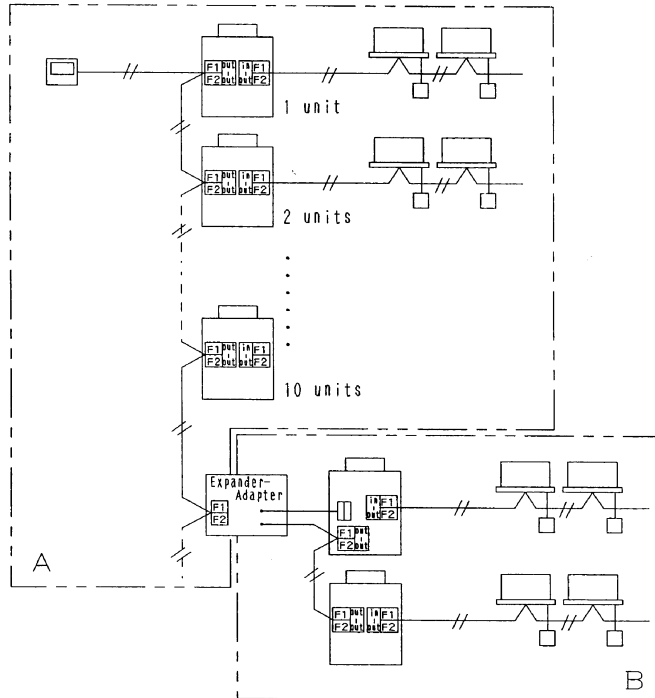

Note Wiring restrictions (see "Electric wiring work") apply to each group A and B.

(V0287)



### 3.4 KRP1B71 / 72 / 73 Adaptor for wiring

**WIRING ADAPTOR INSTALLATION MANUAL**

**KRP1B71 · 72 · 73**

**Accessories** Check if the following accessories are included in the kit.

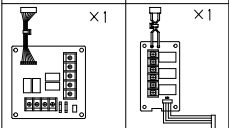
Adaptor			
KRP1B71·72	KRP1B73	PC board support	×4
×1	×1	Clamp	×3
		Installation manual	×1

**Notes**

- Kits vary according to applicable models.
- A special adaptor fixing plate and box are required for the following models, FXFQ...KRP1B98

**1 NAMES OF PARTS**

<KRP1B71 · 72 >

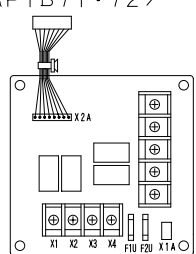

Terminals for operation display

<KRP1B73 >

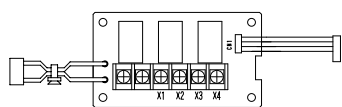

This function can not be used.

Terminals for operation display

**2 ELECTRIC WIRING**

- Refer to the WIRING DIAGRAM attached to the indoor unit before attempting to wire.  
( Make sure wires to units do not pass over the PC board when wiring. )
- Wire the adaptor to the indoor unit as shown below,  
<KRP1B71 · 72 >

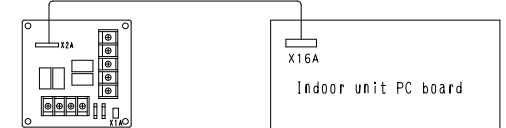

<KRP1B73 >

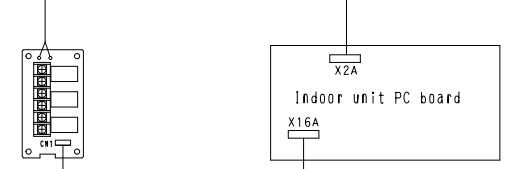

**1 Fetching the operation display signal**

- Attaching an hour meter
- Fan ON display

Output is generated at the contact while the compressor is running.

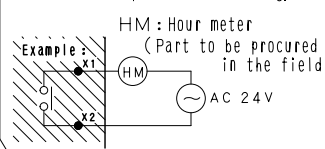
Example:  HM: Hour meter (Part to be procured in the field)

Output is generated at the contact while the fan is running.

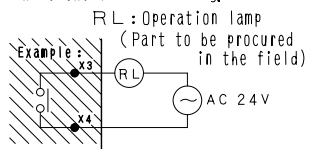
Example:  RL: Operation lamp (Part to be procured in the field)

**2 If optional accessories are installed (auxiliary electric heater, humidifier)**

- Wire correctly in accordance with the attached installation manual.
- Refer to the wiring diagram applied to the indoor unit when running electric wiring.

### ③ INSTALLATION

- Installation differs according to models as shown below.
- Do not bundle low and high voltage wires together.
- Bundle any excess wirings with the attached clamps so as to keep loose wirings off the indoor unit PC board.

#### <Ceiling mounted built-in type>

FXSQ

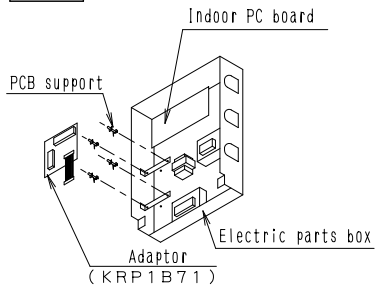

#### <Ceiling mounted cassette type>

FXFQ

Insert the edge of the adaptor into the groove in the adaptor box.

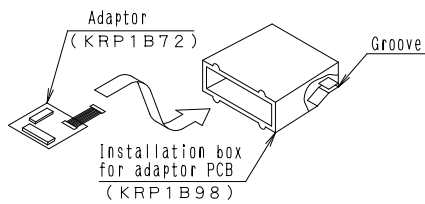

#### <Floor-standing type>

FXLQ

FXNQ

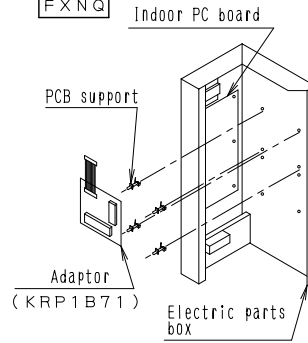

#### <Ceiling mounted duct type>

FXMQ

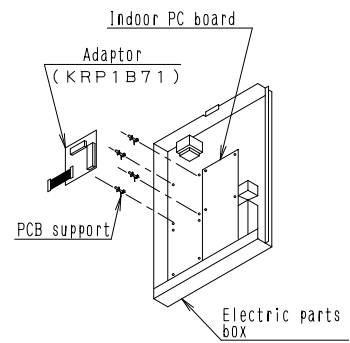

#### <Ceiling suspended type>

FXHQ

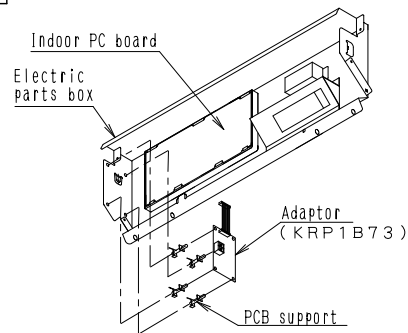

C:2P164806



### 3.5 KRP4A71 / 72 / 73 / 74 Wiring Adaptor for Electrical Appendices

## Daikin Air Conditioner

### Wiring adaptor for electrical appendices (Group control adaptor)

#### Installation manual KRP4A71 • 72 • 73 • 74

**Accessories** Check if the following accessories are included in the kit.

Adaptor × 1	Relay harness × 1 each	PCB support × 4	
	(1)  (2) 	Clamp × 3	Installation manual × 1

**NOTES**

- Kits vary according to applicable models.
- A special adaptor fixing plate and box are required for the following models.

FXAQ..... KRP4A93 FXFQ • FCQ..... KRP1B98 FXHQ • FHQ..... KRP1C93 FXDQ..... KRP1B101	
---	--

#### 1 SYSTEM OUTLINE

This kit enables remote control (ON/OFF control, temperature setting, operation display, error display) and can be used with the following systems though it cannot be used in conjunction with other optional controllers for centralized control.

1. Individual control (Each indoor unit is controlled individually.)

This system requires the following parts.

- Adaptor..... KRP4A71 • 72 • 73 • 74      Any one kit
- Remote controller..... BRC1C71  
(For operation control)

(Ex.) When individually controlling 8 FXSQ12MVJU units  
 KRP4A71 × 8 kits  
 BRC1C71 × 8 kits

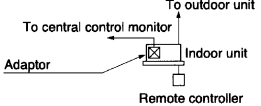

2. Group control (Multiple indoor units are controlled as a group.)

This system requires the following parts.

- Adaptor..... KRP4A71 • 72 • 73 • 74      Any one kit
- Remote controller (For operation control)..... BRC1C71

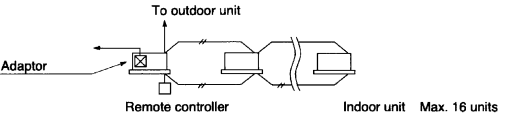

#### 2 NAMES OF PARTS AND FUNCTION

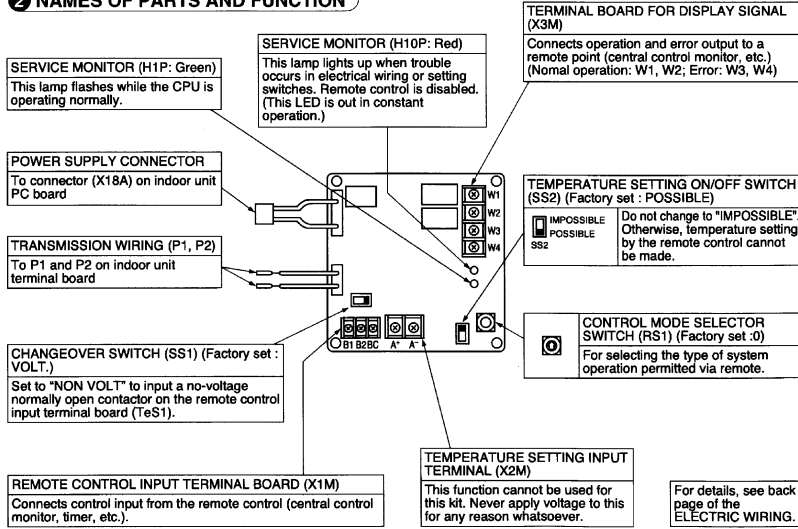

**SERVICE MONITOR (H1P: Green)**  
This lamp flashes while the CPU is operating normally.

**SERVICE MONITOR (H10P: Red)**  
This lamp lights up when trouble occurs in electrical wiring or setting switches. Remote control is disabled. (This LED is out in constant operation.)

**POWER SUPPLY CONNECTOR**  
To connector (X18A) on indoor unit PC board

**TRANSMISSION WIRING (P1, P2)**  
To P1 and P2 on indoor unit terminal board

**CHANGEOVER SWITCH (SS1) (Factory set : VOLT.)**  
Set to "NON VOLT" to input a no-voltage normally open contactor on the remote control input terminal board (TeS1).

**TEMPERATURE SETTING ON/OFF SWITCH (SS2) (Factory set : POSSIBLE)**  
IMPOSSIBLE Do not change to "IMPOSSIBLE".  
POSSIBLE Otherwise, temperature setting by the remote control cannot be made.

**CONTROL MODE SELECTOR SWITCH (RS1) (Factory set :0)**  
For selecting the type of system operation permitted via remote.

**REMOTE CONTROL INPUT TERMINAL BOARD (X1M)**  
Connects control input from the remote control (central control monitor, timer, etc.).

**TEMPERATURE SETTING INPUT TERMINAL (X2M)**  
This function cannot be used for this kit. Never apply voltage to this for any reason whatsoever.

**TERMINAL BOARD FOR DISPLAY SIGNAL (X3M)**  
Connects operation and error output to a remote point (central control monitor, etc.) (Normal operation: W1, W2; Error: W3, W4)

For details, see back page of the ELECTRIC WIRING.

**3 INSTALLATION**

«Ceiling-mounted duct type»

**FXDQ** (Ceiling-mounted duct type)

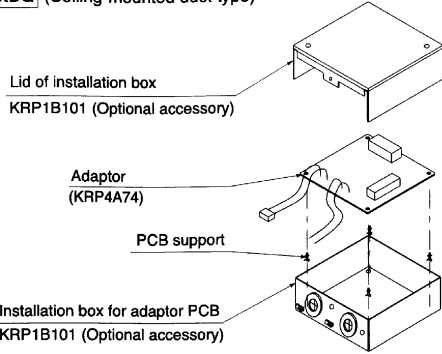

NOTE: Installation box for adaptor PCB is required to install the adaptor.

«Ceiling-mounted cassette type»

**FXFQ** (Fit the edge of the adaptor PCB into the grooves on the adaptor box.)

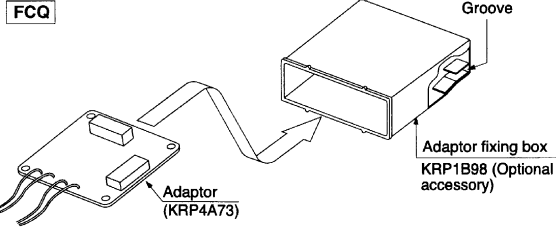

«Ceiling-suspended type»

**FXHQ**

**FHQ**

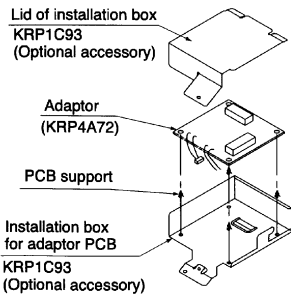

NOTE: Installation box for adaptor PCB is required to install the adaptor.

«Floor-standing type»

**FXLQ**

**FXNQ**

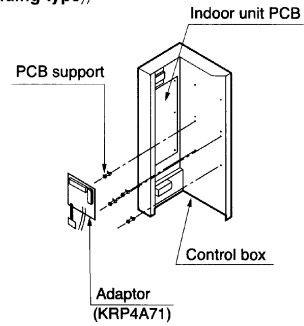

«Ceiling-mounted built-in type»

**FXSQ**

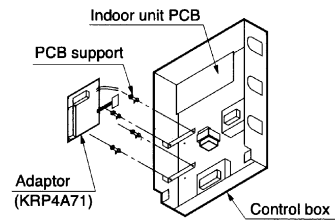

«Ceiling-mounted duct type»

**FXMQ**

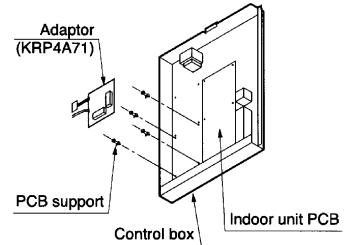

«Wall-mounted type»

**FXAQ**

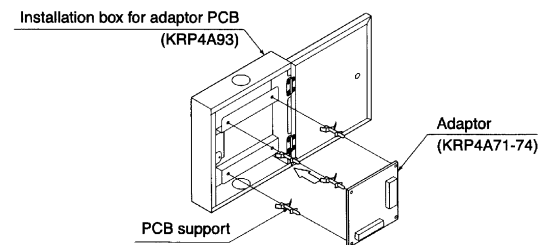

1P161220

**4 ELECTRIC WIRING**

- ① First, wire between the indoor and outdoor units, and then to the separate power sources, and finally between the indoor units and the remote controllers. Then, check if they operate properly. (If wiring for group control by remote controller, check crosswires.)  
For details, see the installation manual of the indoor and outdoor units.
- ② Next, wire between outside units such as the central control monitor, etc. and make the necessary settings.  
For details, see [Wiring to outside units \(central control monitor\)](#).

**Wiring to indoor units**

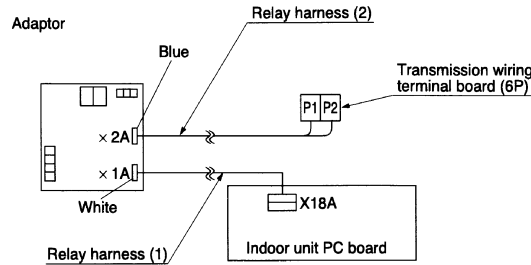

Make connections as shown above, using the attached relay harnesses (1) and (2).

- Connect relay harness (1) to the connector (X18A) on the indoor unit PC board.
- Relay harness (2) has no polarity. Connect it to terminals P1 and P2 on the transmission wiring terminal board inside the indoor unit electric parts box.

**Wiring to outside units (central control monitor)**

**1. Remote control input (operation control)**

Wire as described below. Wiring differs depending on whether using a voltage or no-voltage input.

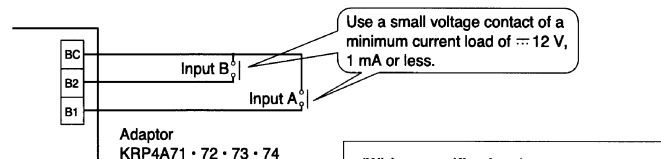
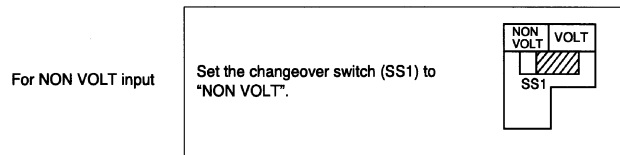
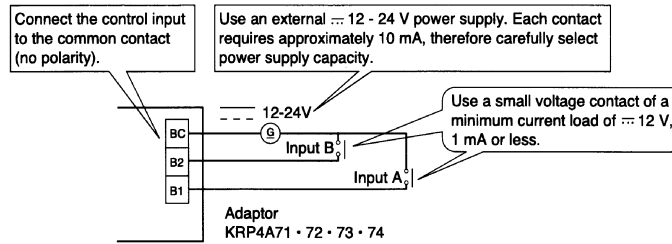
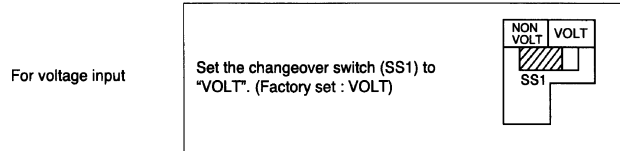

**(Wiring specifications)**  
 Wiring ... Sheathed vinyl cord or cable  
 Gauge ... AWG24-16  
 Length ... Max. 490 ft

**(NOTE)**  
 Keep transmission wiring away from power supply wiring to avoid malfunctions.

**2. Setting the control mode selector switch (RS1)**

Using the control mode selector switch (RS1), select the control mode as described below.



RS1  
CONTROL MODE  
SELECTOR SWITCH

(Factory set)  
"0" position

① For specifying individual display

Position	Function
0	Individual display (input ignored)

② When operating the unit with constant input at input A

Position	Function	When input A is ON	When input A is OFF
1	ON/OFF control impossible by remote controller	Operation (normally ON/OFF control impossible by remote controller)	OFF + ON/OFF control impossible by remote controller
2	Centralized	Operation + ON/OFF control possible by remote controller	
3	OFF control possible by remote controller	Operation + OFF control possible by remote controller (ON control impossible by remote controller)	
4	ON/OFF control possible by remote controller	ON/OFF control possible by remote controller (Operation impossible by optional controller)	

(Note)

- Input B is for forced ON/OFF input. When input B is ON, OFF control is possible but ON/OFF control by the remote controller is impossible, and input A is ignored. When it is OFF, input A is ignored even if selected. It is necessary to reselect input A.

③ When operating the unit using instantaneous input at input A  
(Use an instantaneous input of 200 msec or longer ON time.)

Position	Function	Input A	Input B capacity
5	ON/OFF control impossible by remote controller	Turns OFF system with On input Turns ON system with ON input	Input B is for forced OFF input (when ON, OFF control is possible but ON/OFF control by remote controller is impossible, and input A is ignored).
6	Individual	Turns OFF system with ON input Turns ON system with ON input (Normally ON/OFF control possible by remote controller)	

★ For thermostat control using input B

Position	When input A is ON	When input B is ON
C	ON/OFF control impossible by remote controller (Same as position 5)	Forced thermostat OFF command
D		Energy saving command (*)
E	Individual (Same as position 6)	Forced thermostat OFF command
F		Energy saving command (*)

- Forced thermostat OFF command  
Indoor unit fan only operates.
- Energy saving command (\*)  
The indoor unit operates at 4°F higher (cooling)/lower (heating) the set temperature.

(Notes)

- In such case, even if input A is ON, thermostat control is turned OFF, and all units in the same group will stop.

④ When operating the unit using instantaneous input at input A and B  
(Use an instantaneous input of 200 msec or longer ON time.)

Position	Function	When input A is ON	When input A is OFF
7	ON/OFF control impossible by remote controller	Operation (normally ON/OFF control impossible by remote controller)	OFF + ON/OFF control impossible by remote controller
8	Centralized	Operation + ON/OFF control possible by remote controller	
9	OFF control possible by remote controller	Operation + OFF control possible by remote controller (ON control impossible by remote controller)	
A	ON/OFF control possible by remote controller	ON/OFF control possible by remote controller (Operation impossible by optional controller)	
B	Individual	Operation (normally ON/OFF control possible by remote controller)	OFF (normally ON/OFF control possible by remote controller)

(Notes)

- When set to position 7-A, and using the constant mode for input B, forced stop capacity is enabled (input A is ignored).
- At position B, the constant mode for input B is not used.

**3. Cancelling display signals**

Operation output terminals (W1 and W2) and error output terminals (W3 and W4) are no-voltage normally constant contacts.

(Allowed electric current per contact is between 10 mA and 3 A.)

Normal operation output (Ry1)  
ON when the indoor unit is operating normally.

Error output (Ry2)  
ON when the indoor unit stops because of malfunction or when a transmission error occurs between the adaptor and the indoor unit.

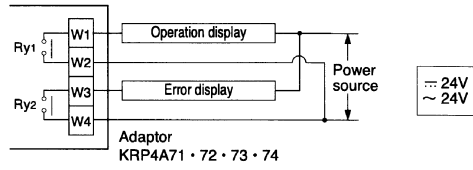

Display output is as described below.

Output	Both Ry1 and Ry2 OFF	Only Ry1 ON	Only Ry2 ON
Display	OFF	Normal operation	System stopped due to malfunction or transmission error generated between adaptor and indoor unit

C:1P161221

### 3.6 DCS302A72 Unification Adaptor for Computerized Control

#### 3.6.1 Function

When connected to the central remote controller, this kit enables unified display (operation/malfunction) and unified control (operation/stop).

##### 1. Unified Display

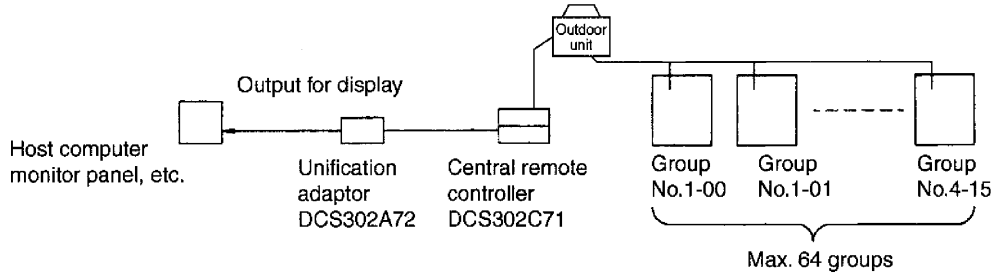

##### 2. Unified Control

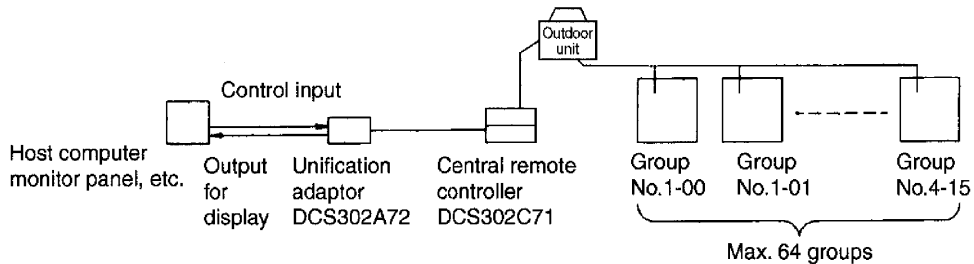

#### 3.6.2 Labels and Functions

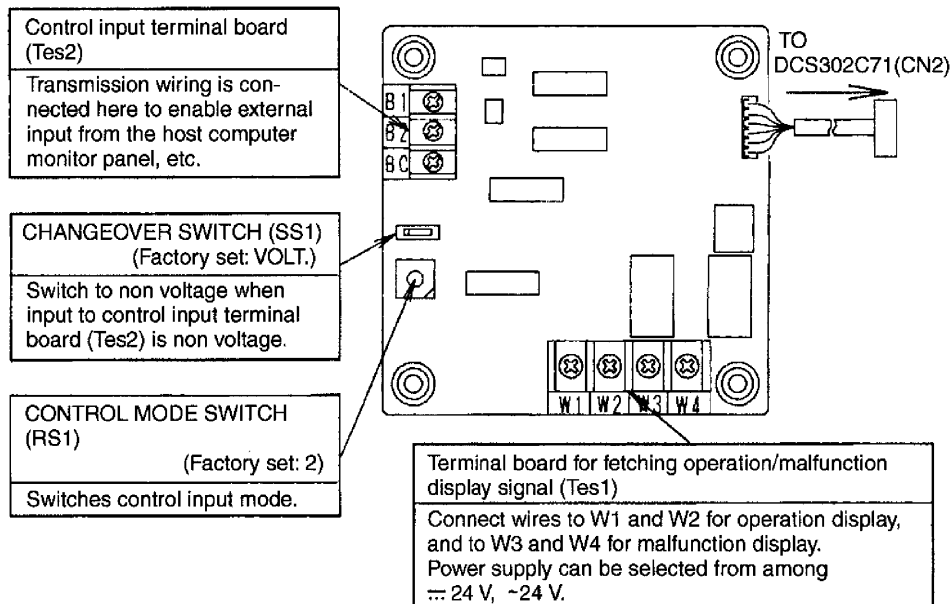

C:1P127045



### 3.6.3 Installation

- Securely install the adaptor inside the electric panel box (field supplied) with the 4 attached screws.
- Install the adaptor 16 feet from the central remote controller to enable cable connection.

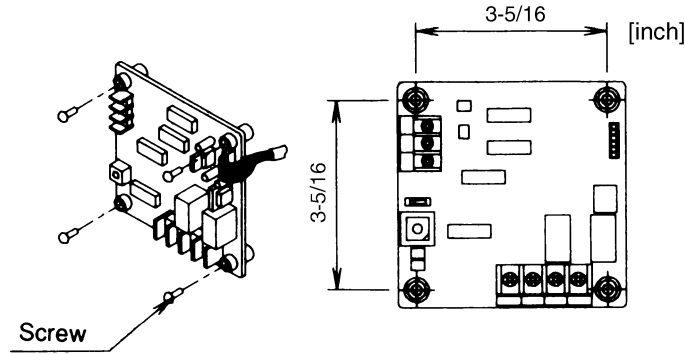

**Note**

1. Do not damage the PC board with your screwdriver or other tools.
2. Install the adaptor inside an electric panel box to protect from electromagnetic waves and dust.

### 3.6.4 Electrical Wiring Work and Initial Setting

First, wire between the indoor and outdoor units, and between each unit and the power supply source. Then, wire between the indoor unit and remote controller. Finally, check that operation is normal.

**For details, refer to the installation manuals for the indoor and outdoor units.**

Next, wire between the indoor unit and the central remote controller. Then, wire the central remote controller to the power supply source and make the necessary settings. Finally, check that operation is normal.

**For details, refer to the installation manuals for the central remote controller.**

Wire between the unification adaptor for computerized control and the central remote controller.

**Refer to manual: WIRING TO THE CENTRAL REMOTE CONTROLLER**

Set the CHANGE OVER SWITCH and CONTROL MODE SWITCH. Wire to the host computer monitor panel or other external input device.

**Refer to manual: WIRING TO EXTERNAL INPUT DEVICES**

**Wiring to The Central Remote Controller**

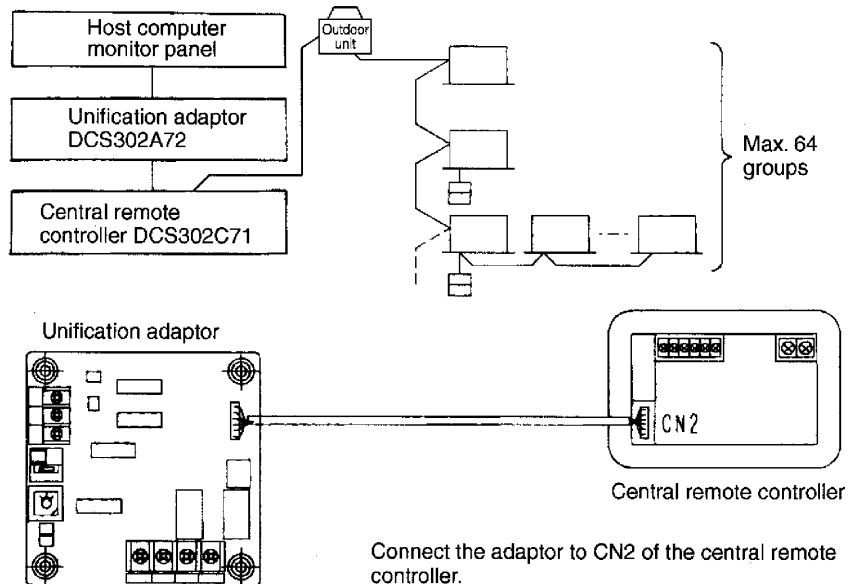

### Wiring to External Input Devices

Wire specifications:

2- conductor, 18 AWG, stranded, non-shielded copper cable / PVC or vinyl jacket

Max. length: 490 ft.

#### 1. Control Input: Unified Operation/Stop

Wire according to input carrying voltage or not, as shown in the following diagrams:

(1) Input with Voltage:

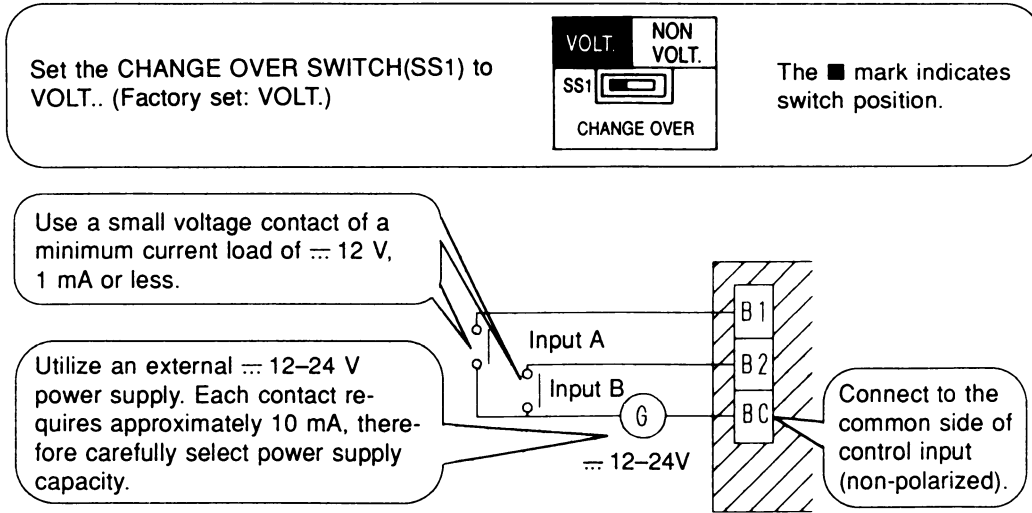

(V0209)

(2) Input with Non Voltage:

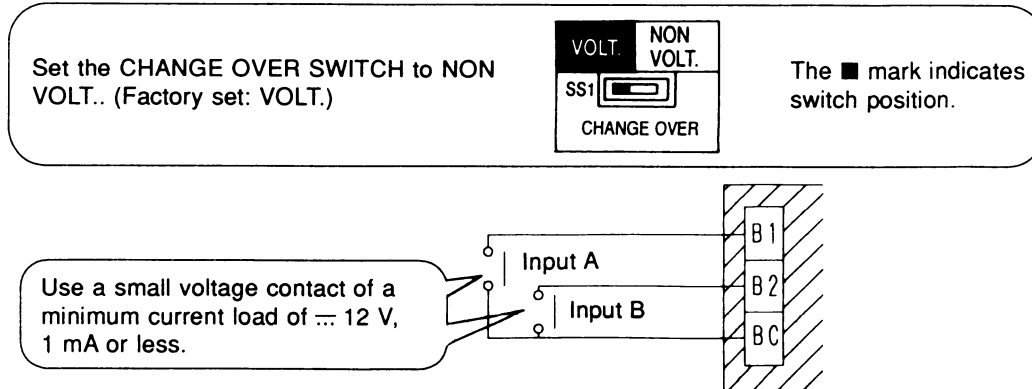

2. Control Mode Switch (RS1) Setting

Control mode can be selected from input A and B at this switch on the PC board adaptor. (Factory set: 2)

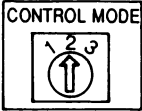

(1) For Normal Operation by Input A

Position	Input A
2	OFF → ON: Unified Operation
	ON → OFF: Unified Stop

■ Input B can be disregarded.

(2) For Instantaneous Operation by Input A and B

Use an instantaneous input of 400 milli-sec. or more at ON time.

Position	Input A	Input B
3	On: Unified Operation	ON: Unified Stop

(3) Do not set the switch to position 1. This switch can be set at any time.

3. Fetching the Display Signal

Terminals W1 - W4 are non-voltage contacts used in normal operation to output operation display (W1 and W2) and malfunction display (W3 and W4) signals.

The allowable current per contact is 10 mA - 3A.

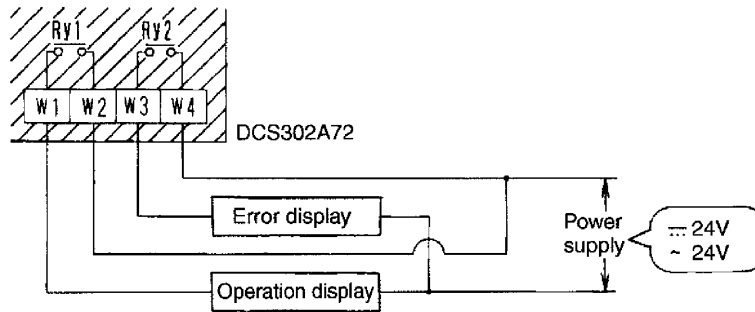

Output conditions are indicated as shown in the following table:

When Ry1 and Ry2 are OFF	When only Ry1 is ON	When only Ry2 is ON
All indoor units are stopped.	No error has occurred with the indoor units, and at least 1 unit is operating.	At least 1 unit has stopped operating due to malfunction, or a communications error has occurred between the central remote controller and the indoor unit.

C:1P127045



- Daikin Industries, Ltd.'s products are manufactured for export to numerous countries throughout the world. Daikin Industries, Ltd. does not have control over which products are exported to and used in a particular country. Prior to purchase, please therefore confirm with your local authorized importer, distributor and/or retailer whether this product conforms to the applicable standards, and is suitable for use, in the region where the product will be used. This statement does not purport to exclude, restrict or modify the application of any local legislation.
- Ask a qualified installer or contractor to install this product. Do not try to install the product yourself. Improper installation can result in water or refrigerant leakage, electrical shock, fire or explosion.
- Use only those parts and accessories supplied or specified by Daikin. Ask a qualified installer or contractor to install those parts and accessories. Use of unauthorized parts and accessories or improper installation of parts and accessories can result in water or refrigerant leakage, electrical shock, fire or explosion.
- Read the User's Manual carefully before using this product. The User's Manual provides important safety instructions and warnings. Be sure to follow these instructions and warnings.

If you have any inquiries, please contact your local importer, distributor and/or retailer.



© 2004 Daikin Industries, Limited.

Daikin®, Daikin AC™, Absolute Comfort™, VRV® and REFNET™ are trademarks pending or registered trademarks of Daikin Industries, Limited. All rights reserved. LonWorks® and LON® are registered trademarks of Echelon Corporation. BACnet® is a Data Communication Protocol for Building Automation and Control Networks, developed under the auspices of the American Society of Heating, Refrigerating and Air-Conditioning Engineers (ASHRAE).



JMI-0107



JQA-1452

**About ISO9001**

ISO 9001 is a plant certification system defined by the International Organization for Standardization (ISO) relating to quality assurance. ISO 9001 certification covers quality assurance aspects related to the "design, development, manufacture, installation, and supplementary service" of products manufactured at the plant.



EC99J2044



JQA-E-90108

**About ISO 14001**

ISO 14001 is the standard defined by the International Organization for Standardization (ISO) relating to environmental management systems. Our group has been acknowledged by an internationally accredited compliance organisation as having an appropriate programme of environmental protection procedures and activities to meet the requirements of ISO 14001.

**Dealer**

**DAIKIN AC (AMERICAS), INC.**

1645 Wallace Drive, Suite 110  
Carrollton, TX75006

info@daikinac.com  
www.daikinac.com

©All rights reserved

● Specifications, designs and other content appearing in this brochure are current as of May 2007 but subject to change without notice.